

DIY-Kit

AGE
14+

JSPB
JET-LAB Ø
S E R I E S

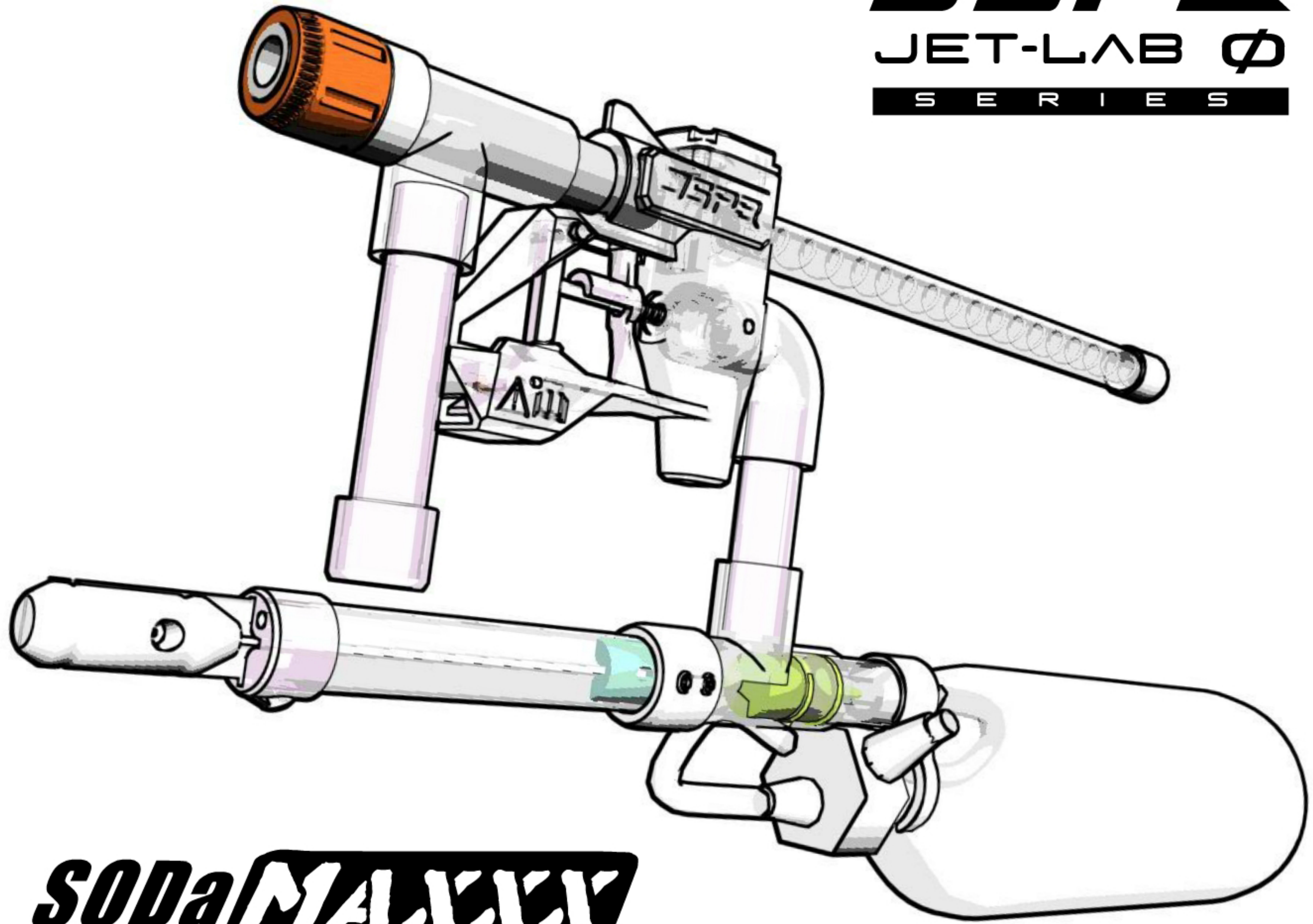

SODaMAXXX

VER:1.5.1 by: Ezekiel lin
Wear goggles at all times.
操作或遊戲時請戴護目鏡。

! Warning: Choking hazard-may contain small parts.
not for childer under 3years.
警告:內含細小零件,遠離幼童請勿吞食。



JSPB JET-LAB Ø SODaMAXXX
噴射實驗室 Ø 極限蘇打

Read and fully understand the instructions prior to use.
The supervising adult should also read the instructions if a child is using the model.Keep instructions for future reference.
使用前請詳細閱讀理解說明書。
如果孩童操縱使用,監護人也需閱讀說明書。

Items 請自備 required:

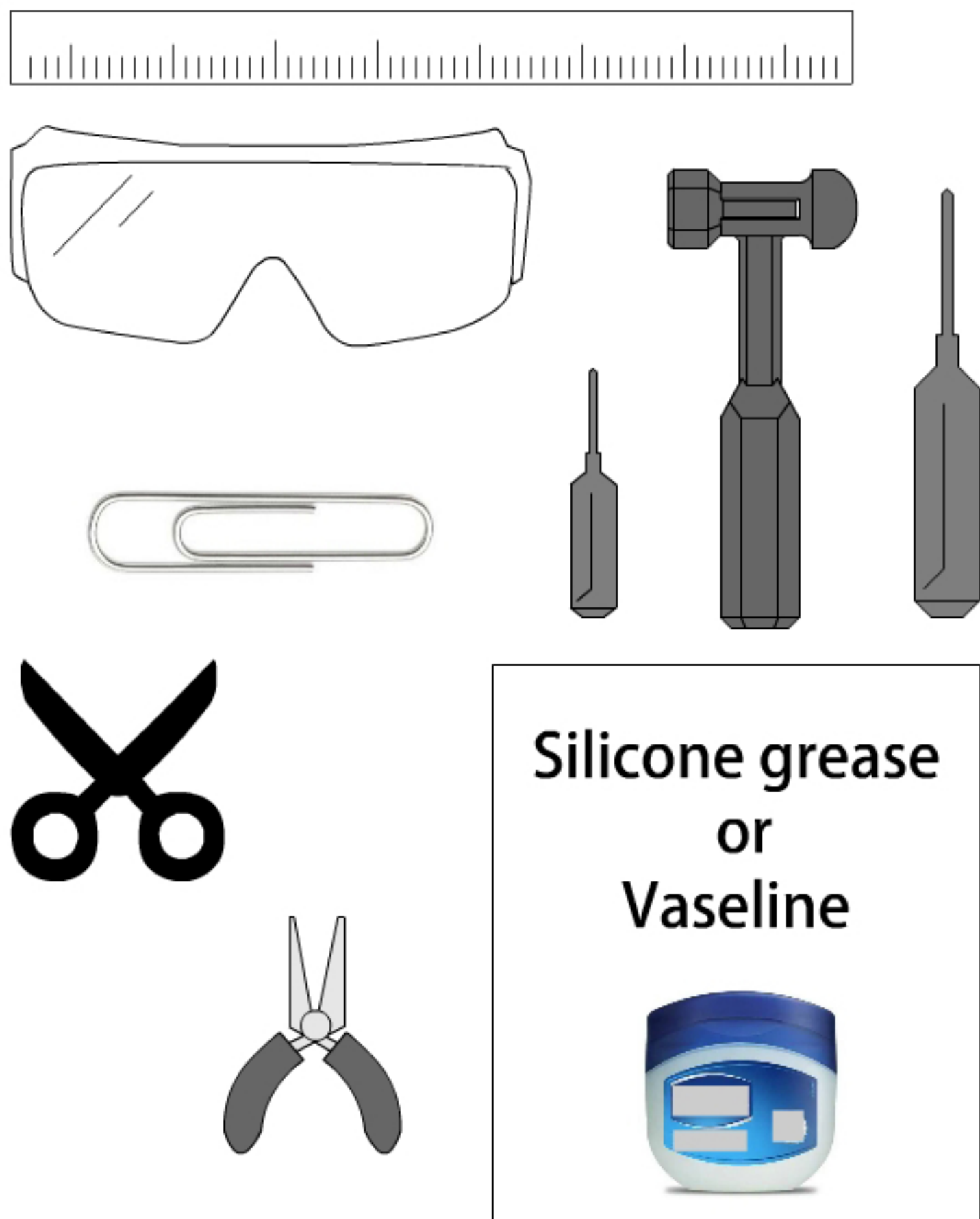

Glue



Multifunction

or



Pipe-Glue
(ASAA)
Vinyl adhesive for rigid vinyl products



SODA BOTTLE



TEA, WATER, JUICE.

矽油 Lubricant

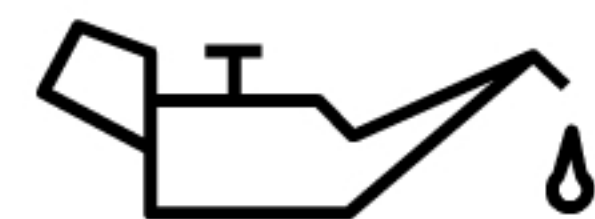

Silicon Oil
1000~10000 CPS

TIPS:

✗

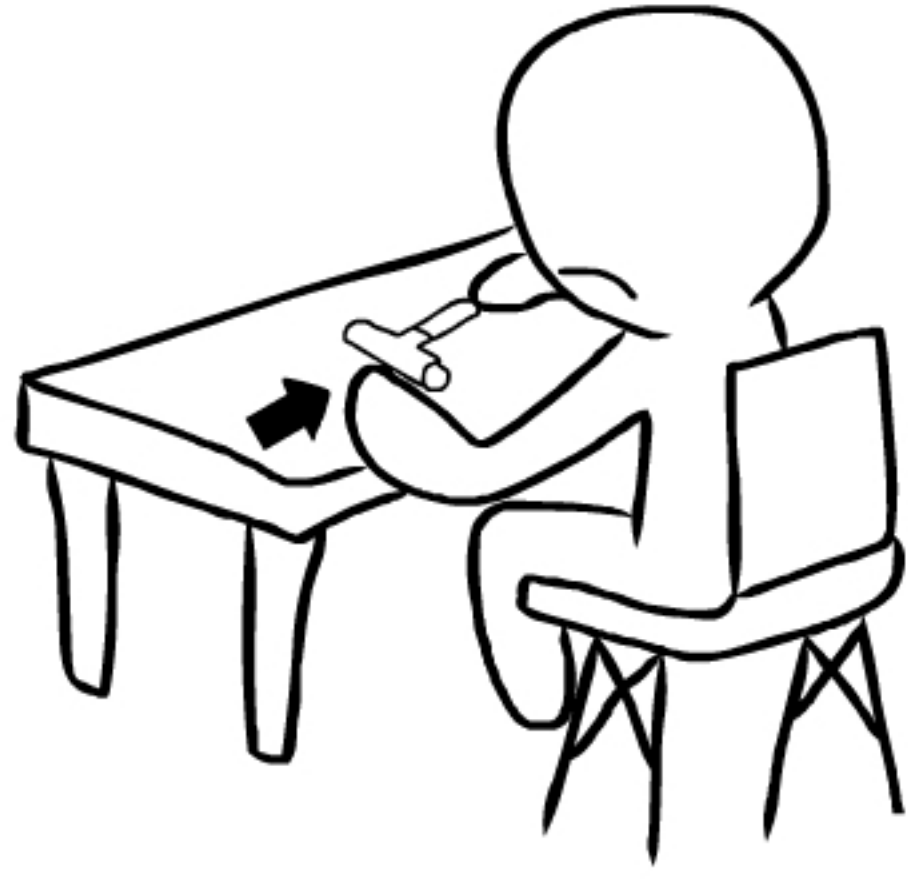

✓

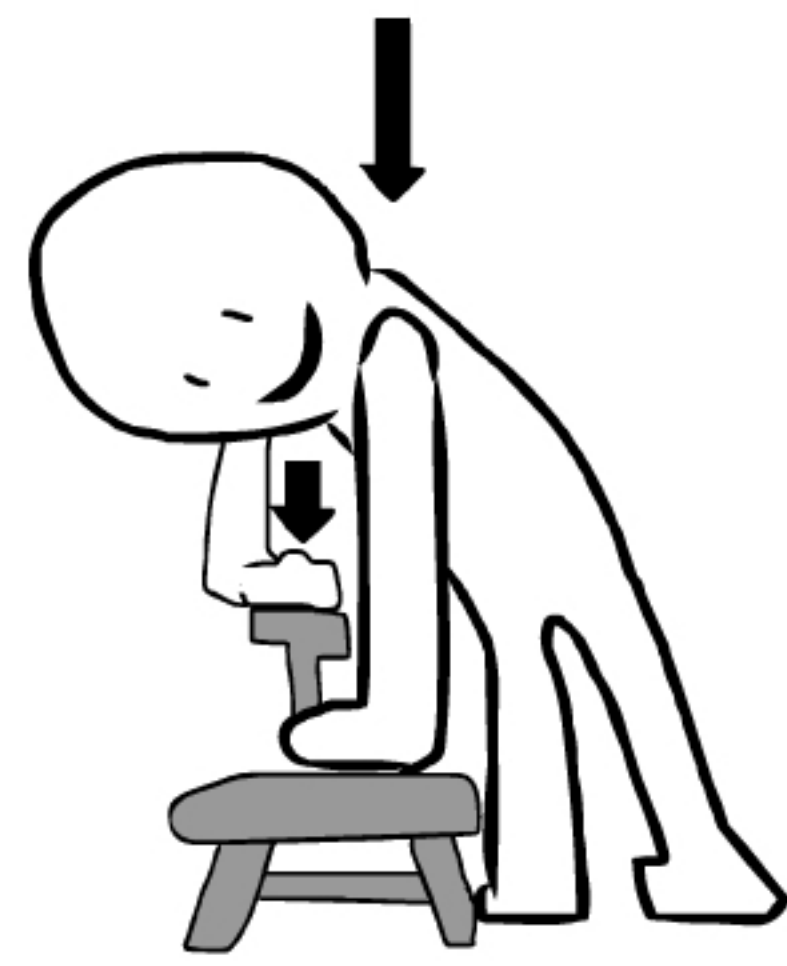

✓

Safety first

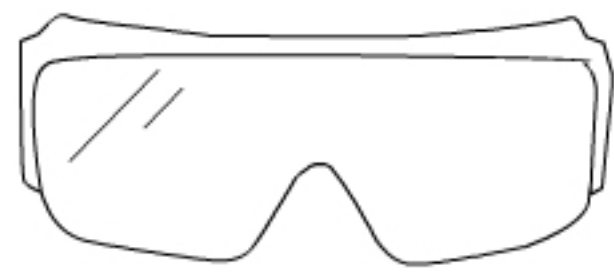

✓

Useful tool

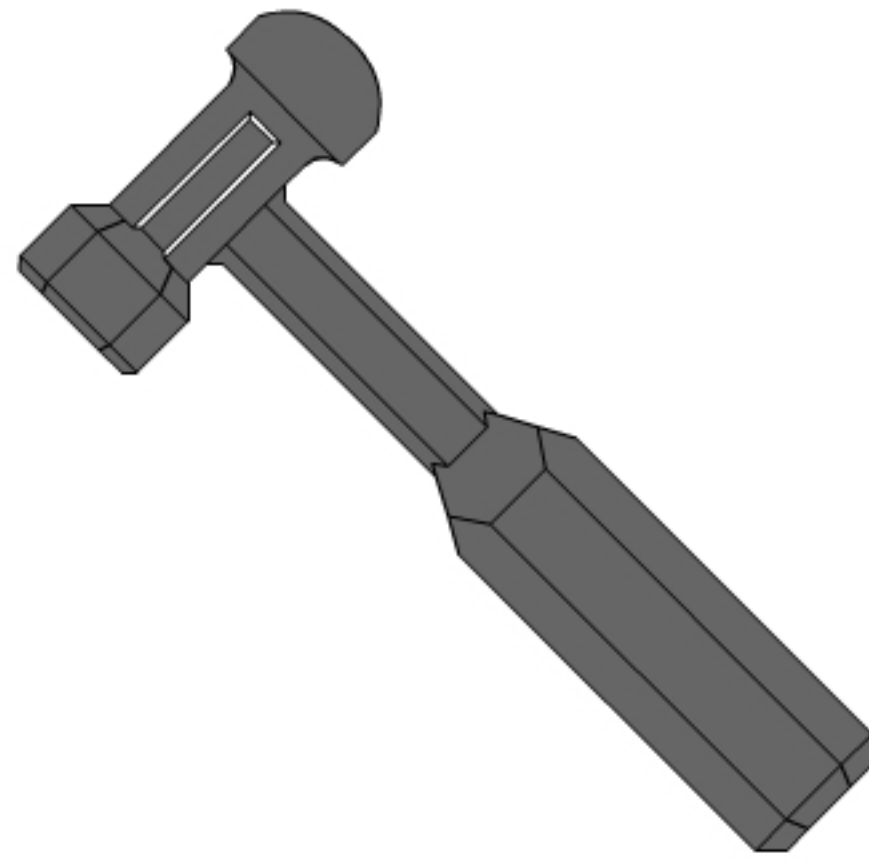

✓

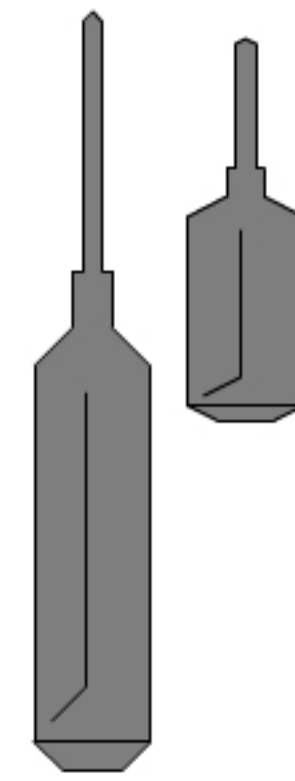

✗

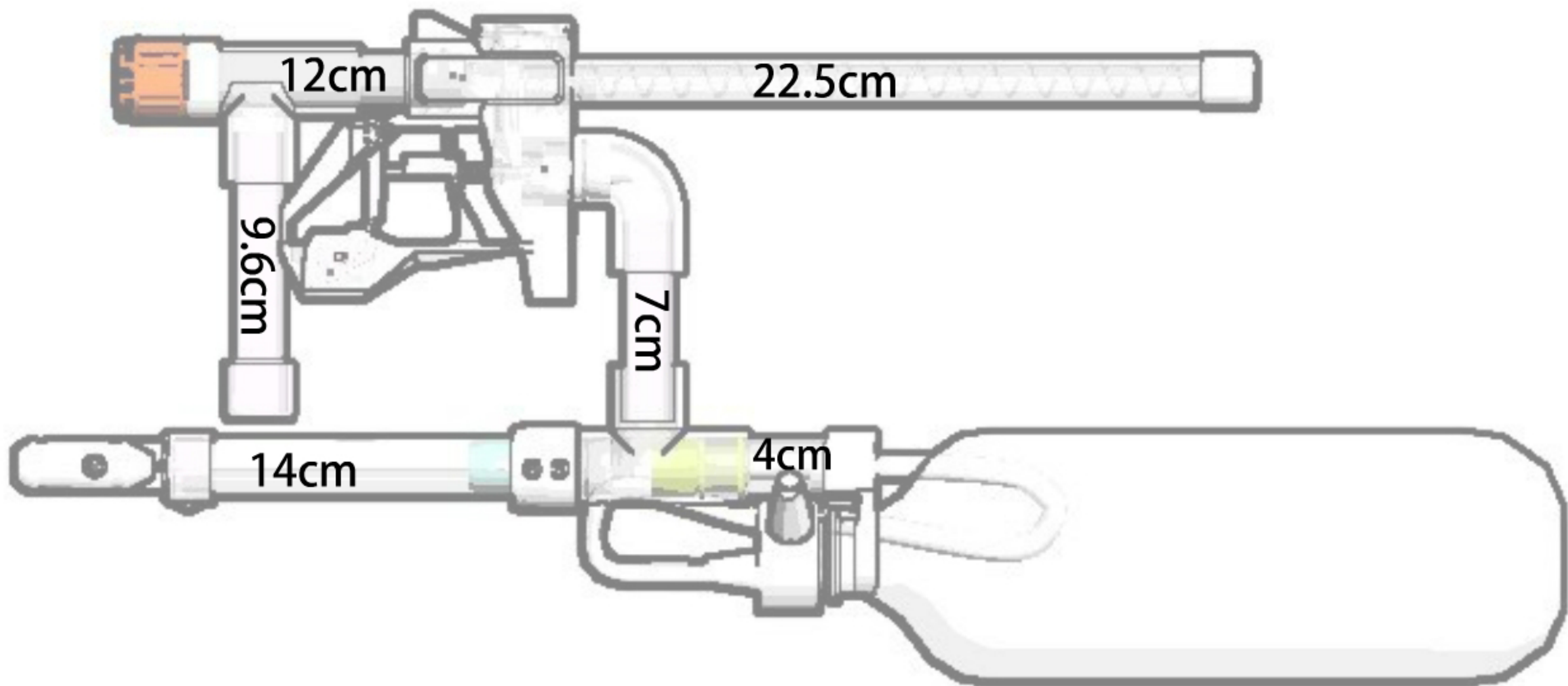

✗

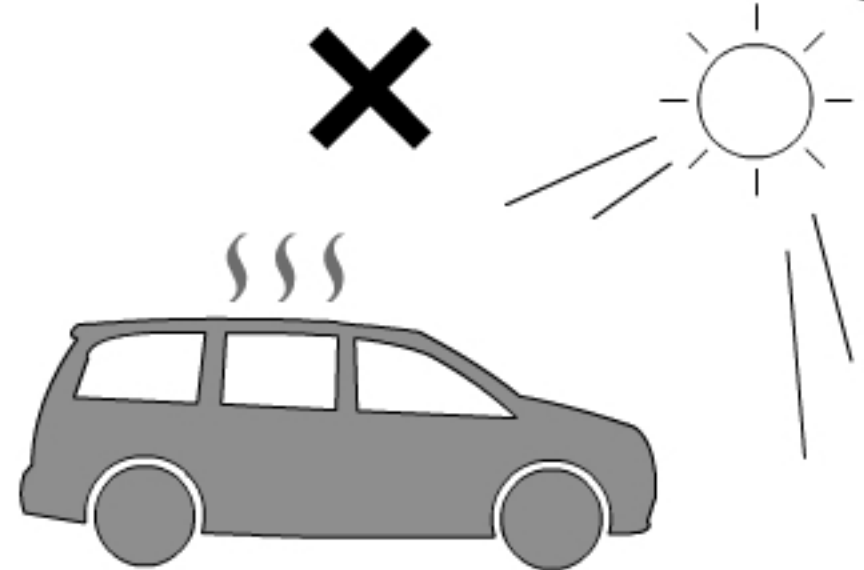

Don't leave blaster in hot cars

✗

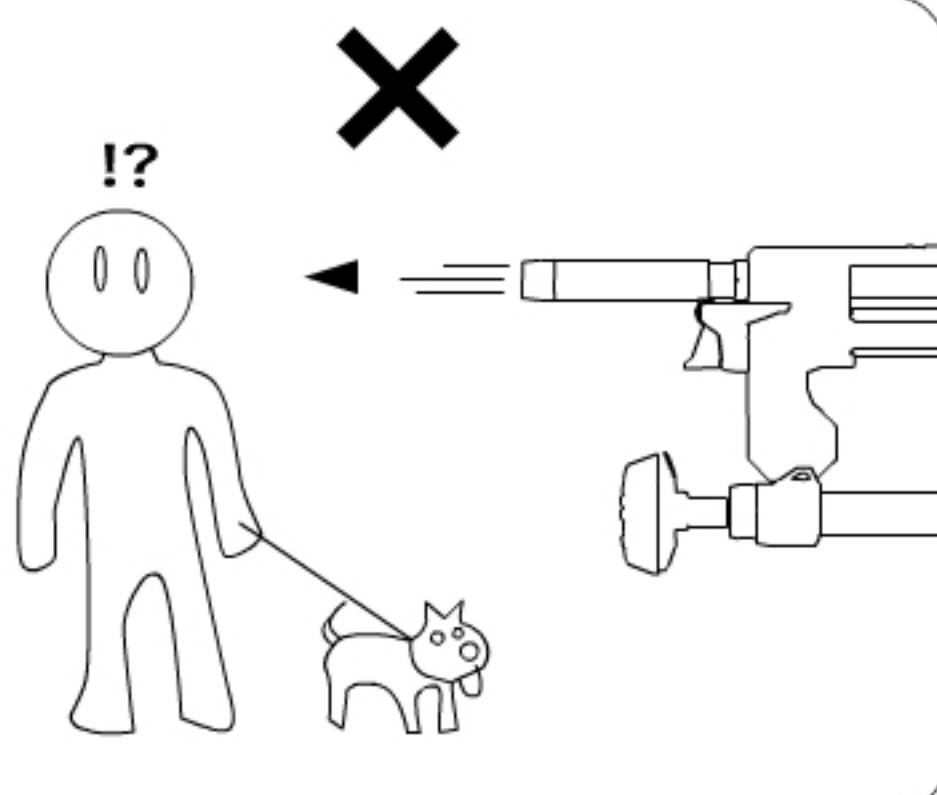

✗

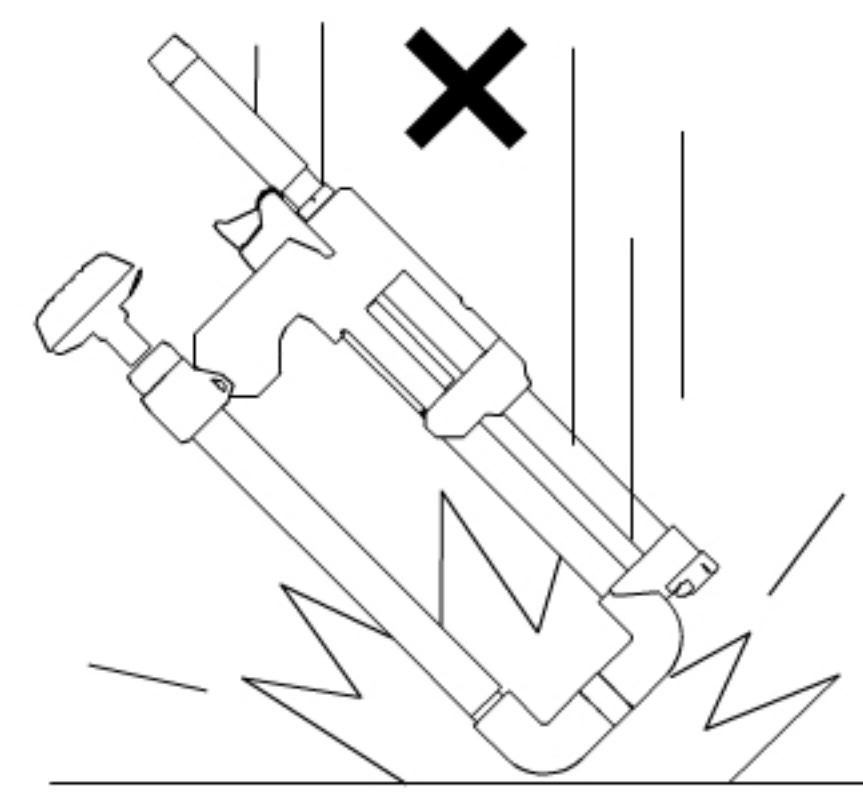

Read and fully understand the instructions prior to use.
The supervising adult should also read the instructions if a child is using the model.Keep instructions for future reference.

使用前請詳細閱讀理解說明書.如果孩童操縱使用,監護人也需閱讀說明書.

▲ 警告

- 14歲以下請家長陪同使用。
- 細小零件避免兒童吞食。
- 小心操縱工具以免受傷。
- 請勿在公共空間驚嚇或攻擊他人。
- 請勿再捷運,火車,飛機上遊玩。
- 請勿瞄準頭或臉。
- 請勿攻擊他人財產或是動物。
- 黑色塗裝攜帶時必須放入槍袋。
- 改造請依照當地法規合法改造。

▲ 注意

- 製作或遊戲時請戴上護目鏡。
- 操縱黏膠或潤滑油不能接觸眼睛,如果不慎接觸請大量沖水並且就醫。
- 3D列印材質PLA,水管為PVC。
- 小心水管與零件銳邊,使用砂紙打磨。
- 變形損壞的JSPB請勿再使用。
- 請先清點材料,如有缺件請聯絡購買處。

▲ WARNING!

- Use under adult supervision.
- Not suitable for children under 3 years of age.
- Care should be taken when using tools and modeling knives,as these can cause personal injury.
- Keep out of reach of small children when assembling.Children must not be allowed to touch tools or put any parts or packaging material in their mouths.
- Do not use glue near open flame and make sure to ventilate room to prevent poisoning/intoxication.
- Never play the blaster on streets,near small children or in a crowded area.

▲ CAUTION!

- Wear goggles at all times.
- Parts using sandpaper make shure not to leave sharp points or edges
- Lubricants,glue.must not be inhaled or ingested.if accidental exposure occurs ,immediately flush with water and seek medical attention.
- Do not use the model if any parts are damaged or deformed.
- Care should be taken with parts with sharp points and edge.

START!

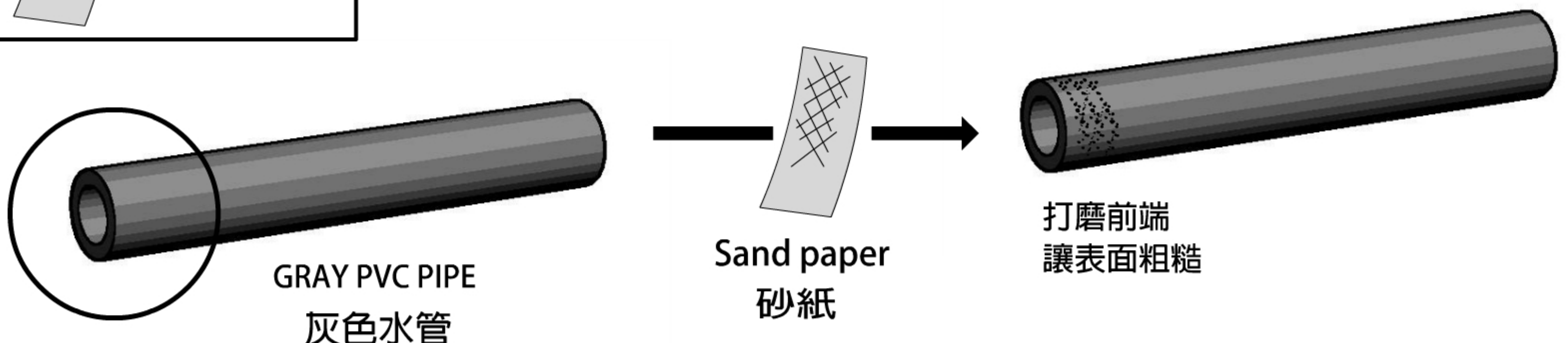
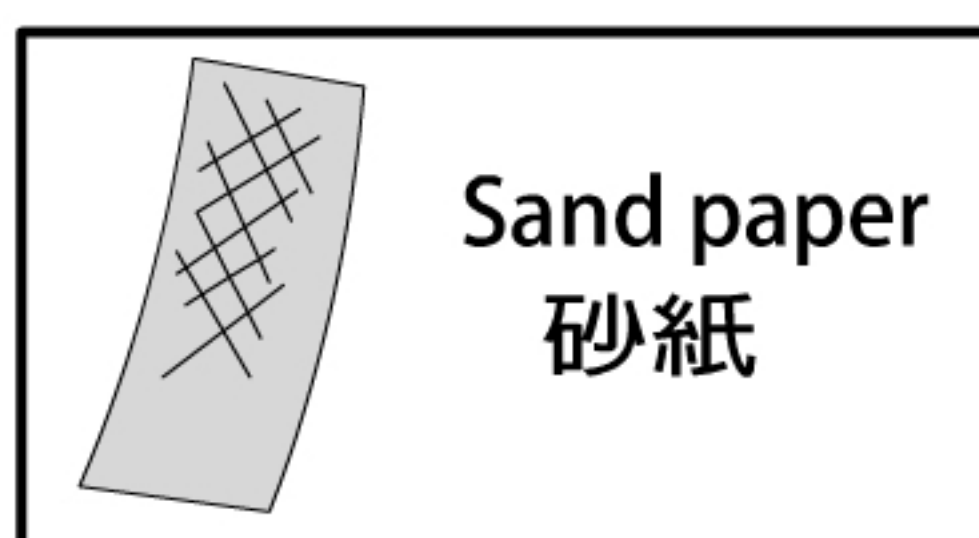

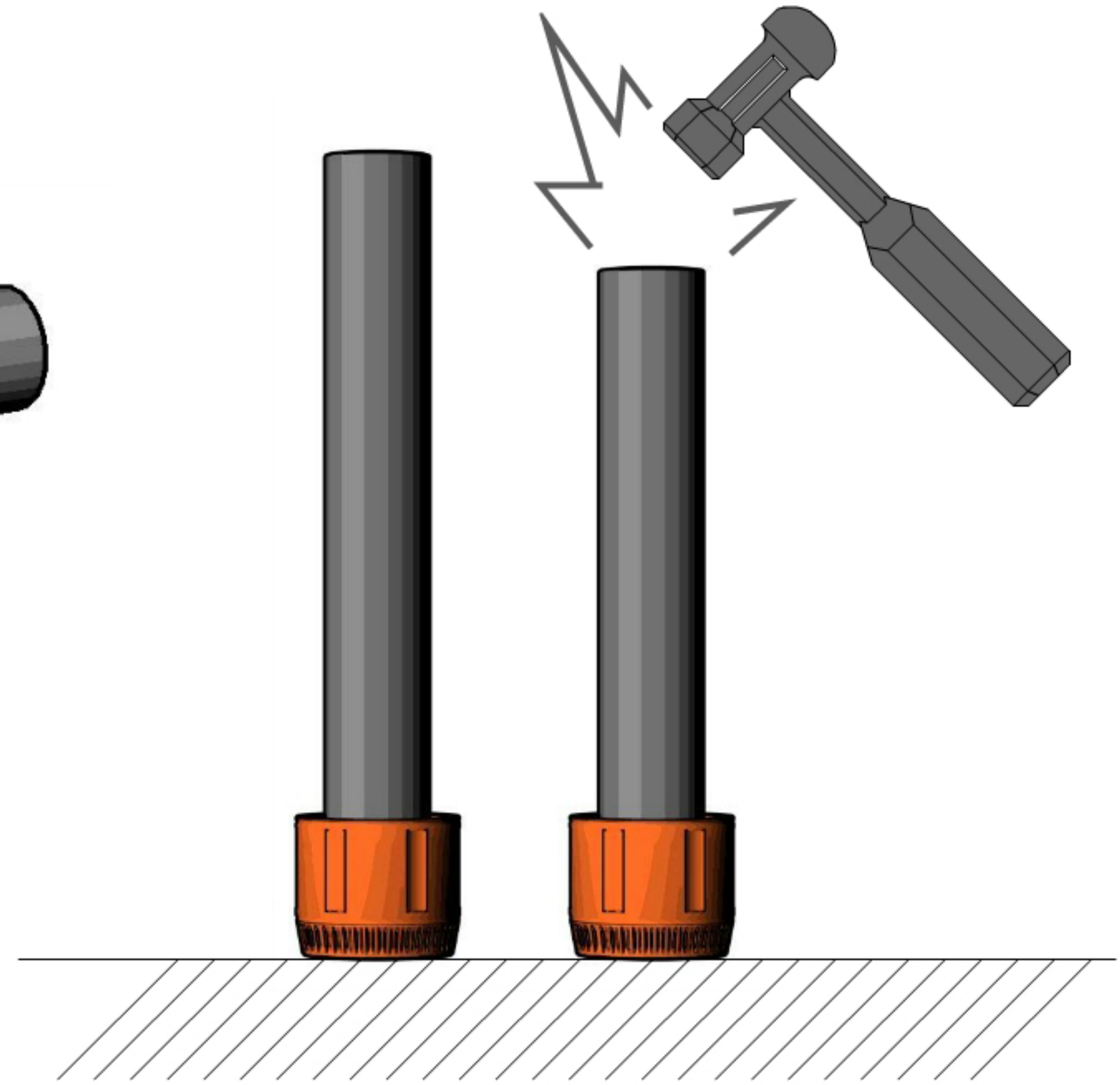
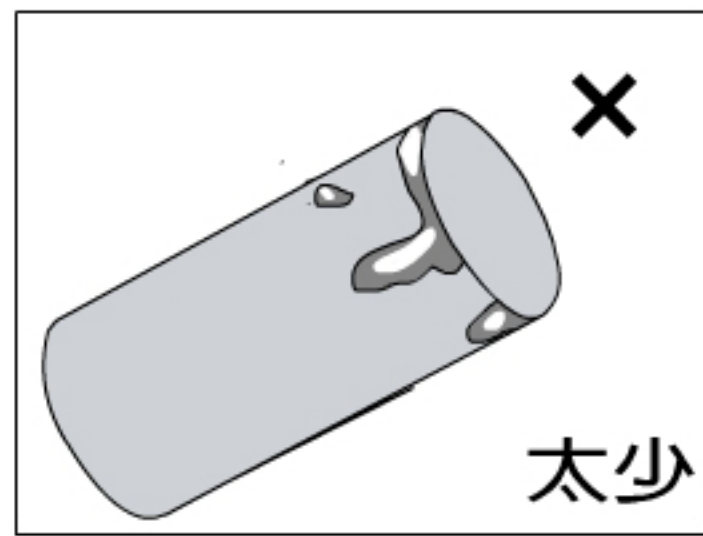
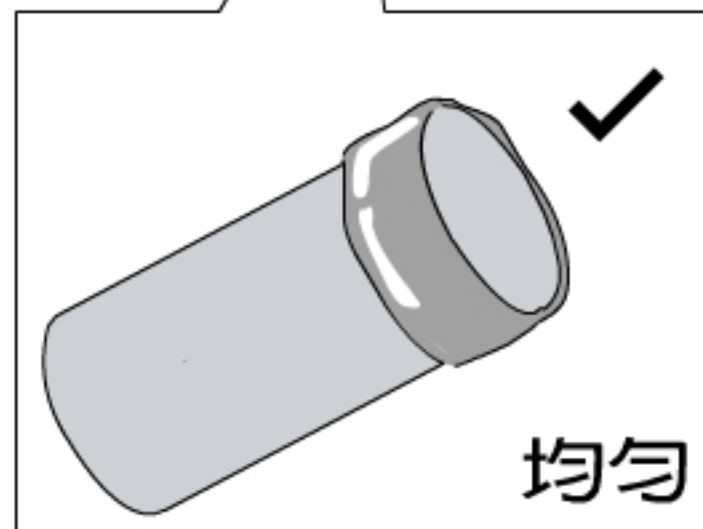
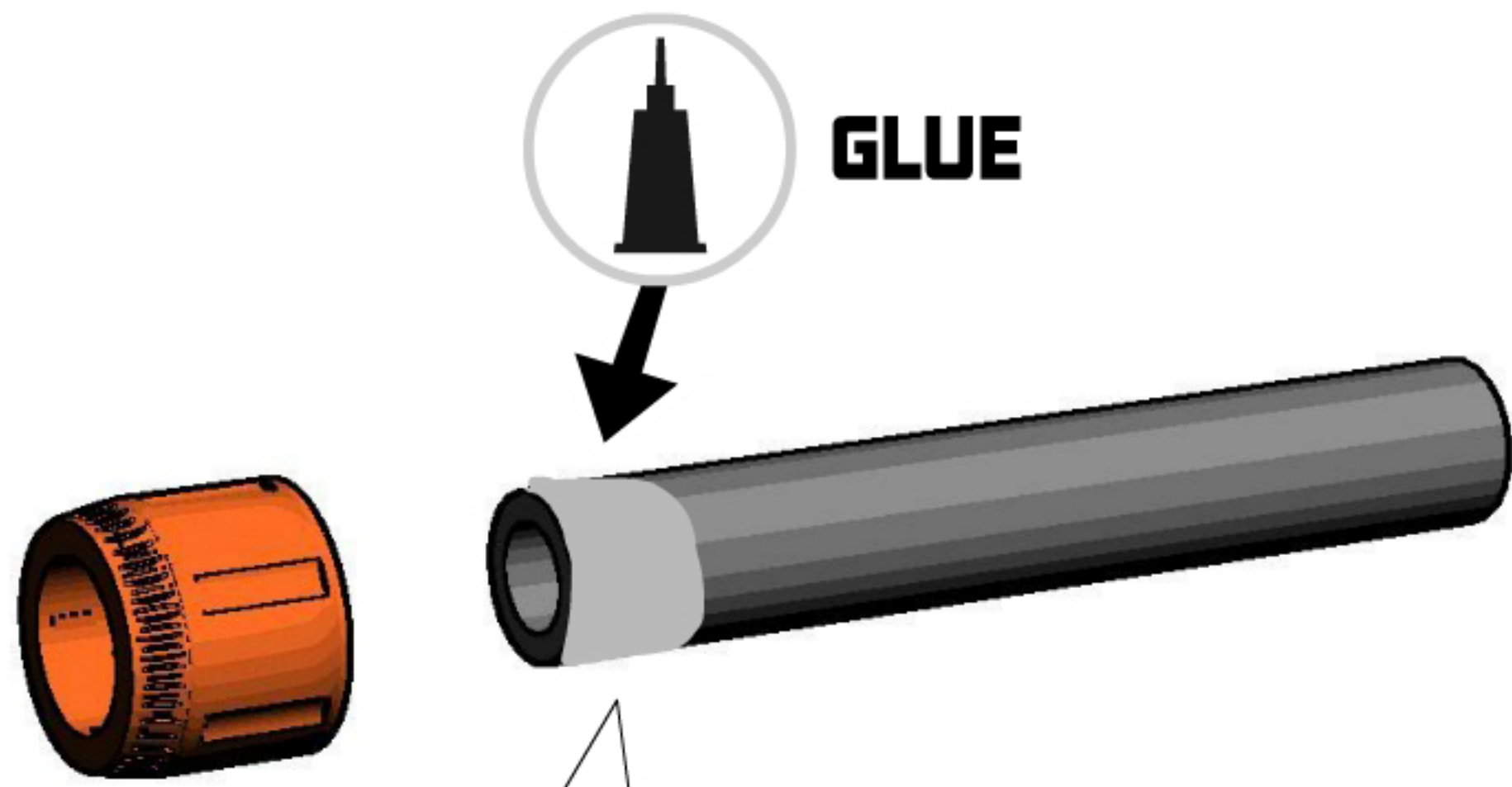

This ICON represents the place where sanding is applied

此圖示代表需使用砂紙磨過
所有水管連接處都需使用砂紙磨過

IMPORTANT! 重要!



This ICON represents the place where glue is applied

此圖示代表需使用膠水黏接,可使用多功能塑膠用膠水
打磨後再連接

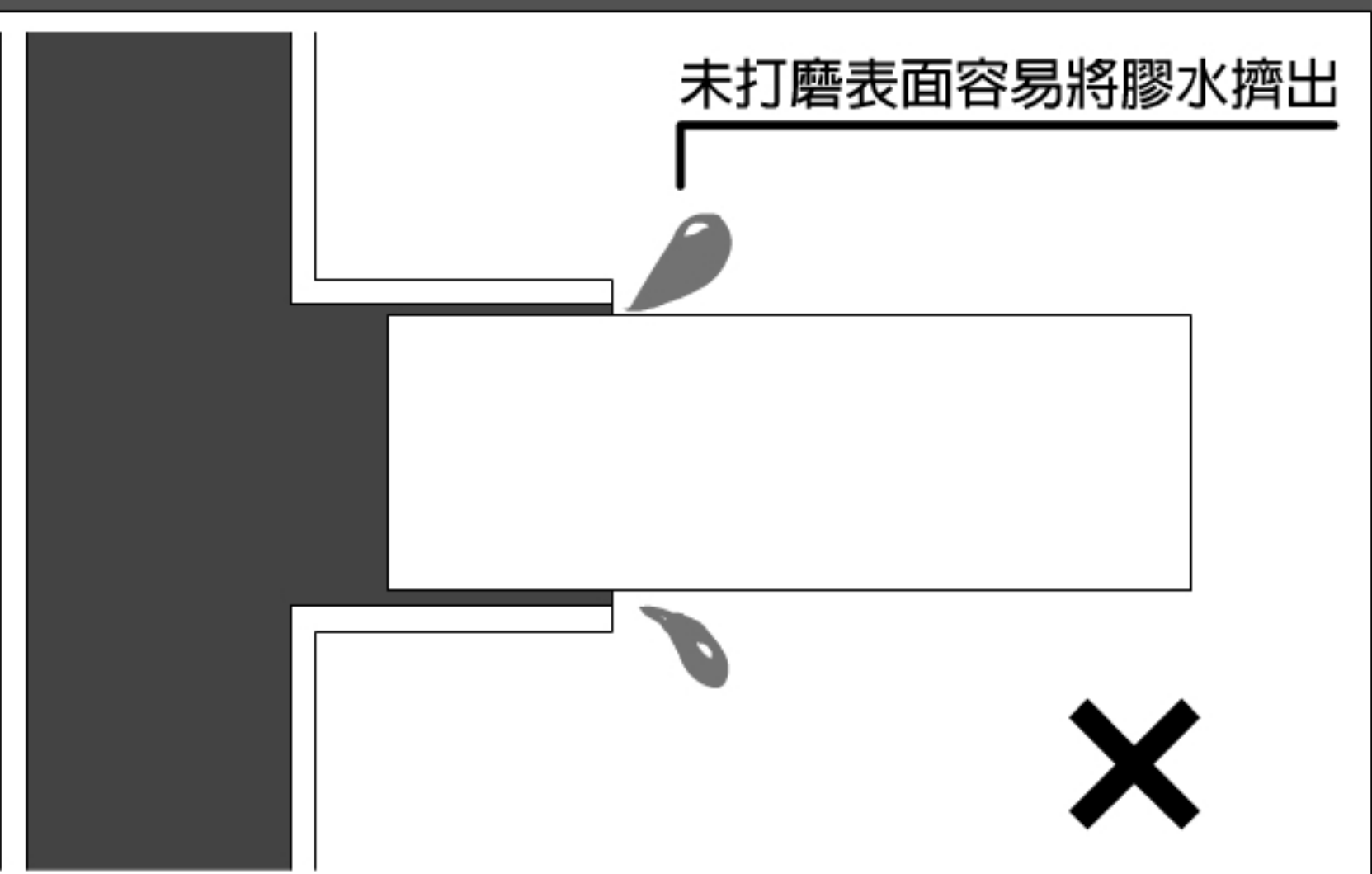
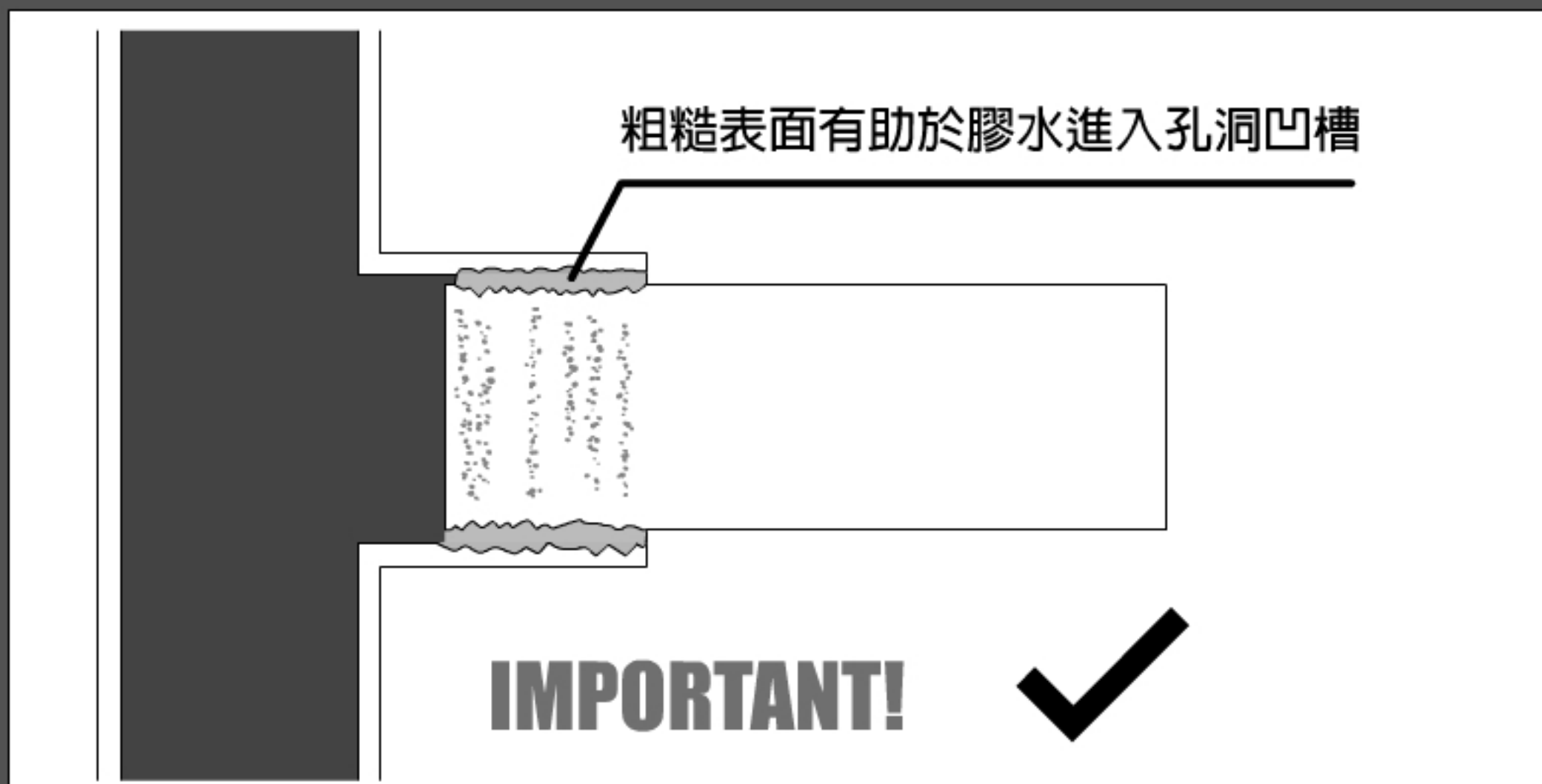

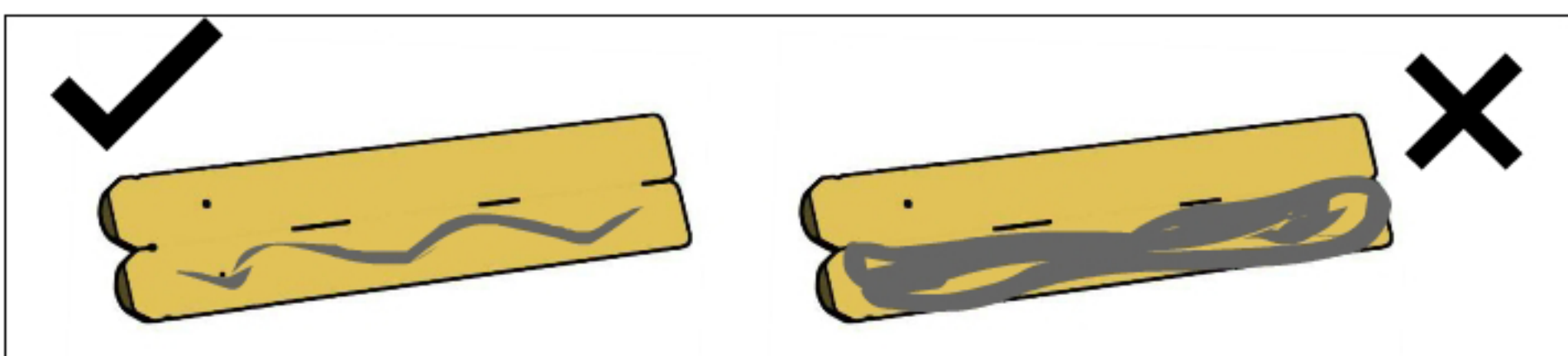
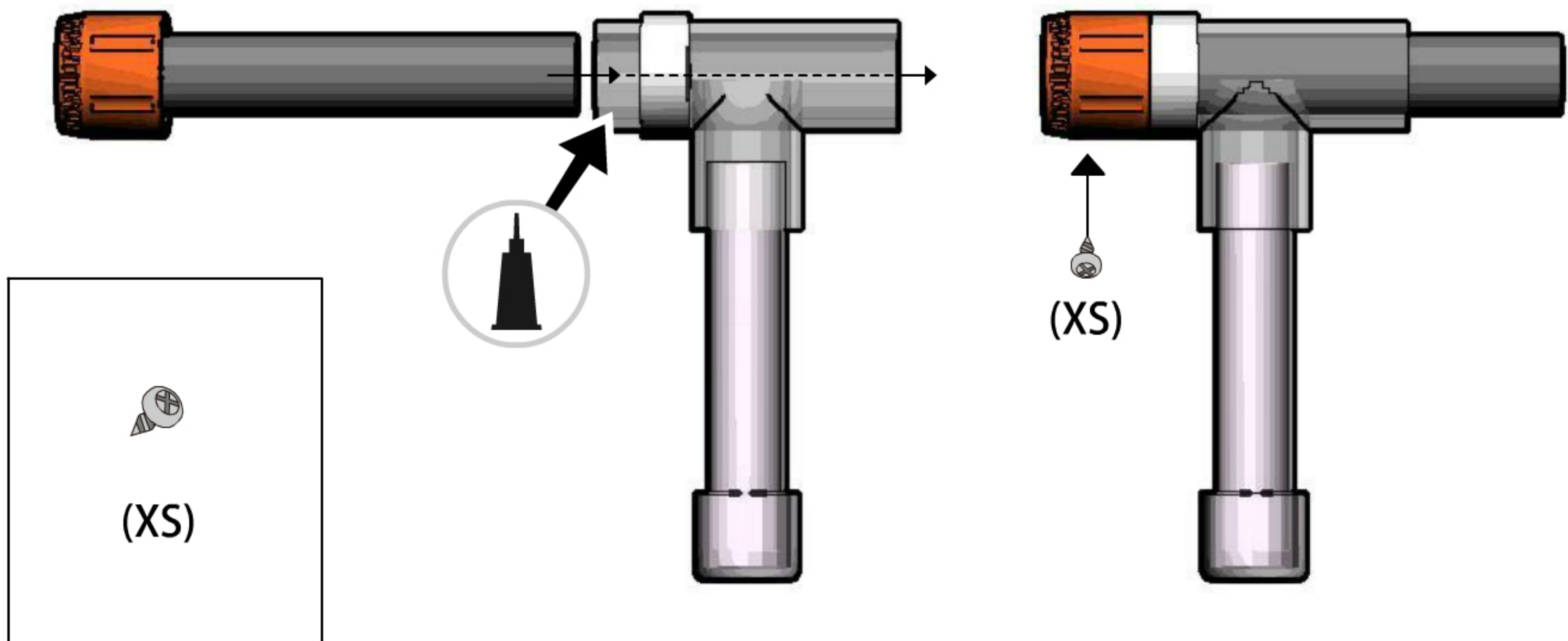
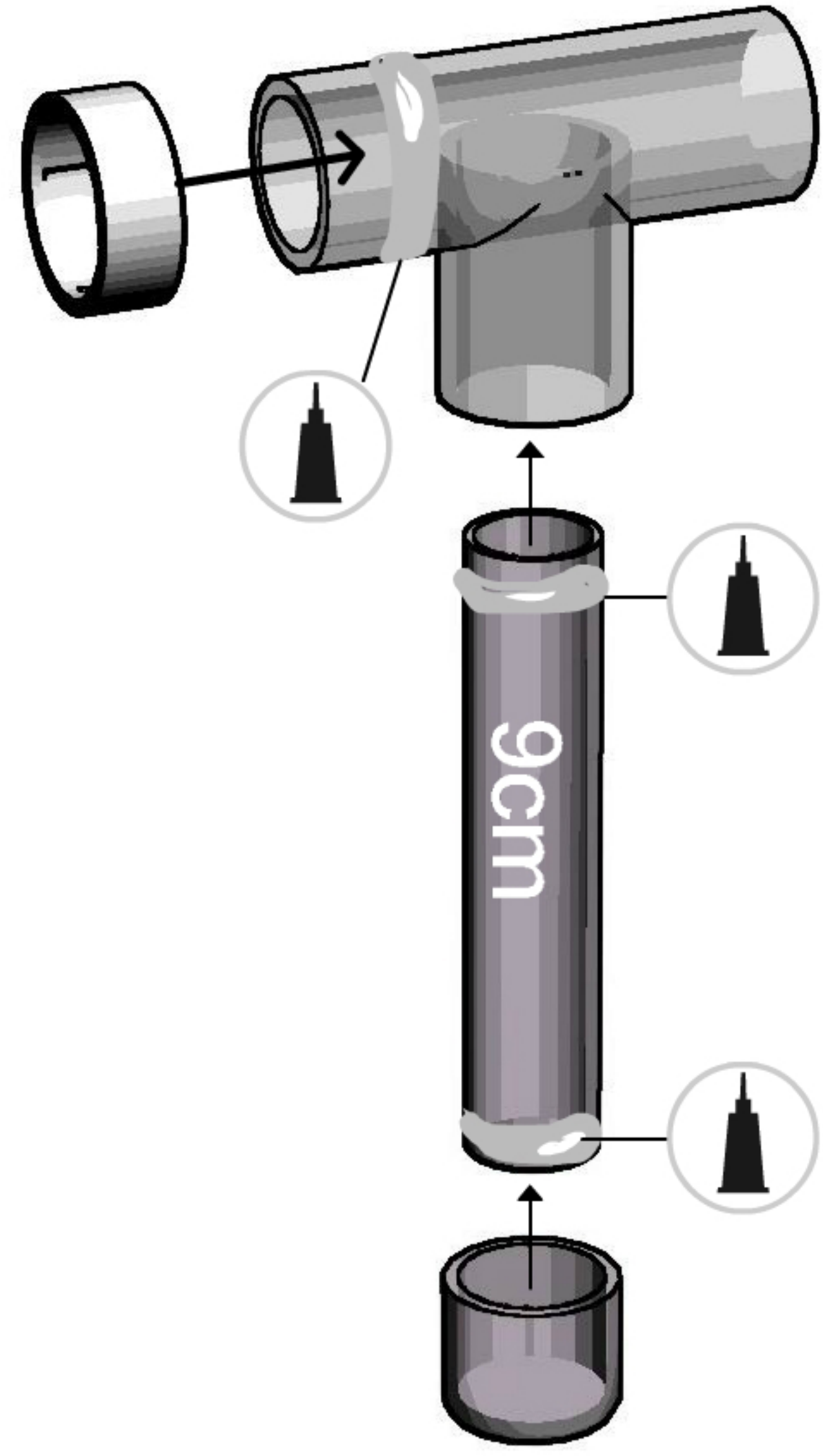
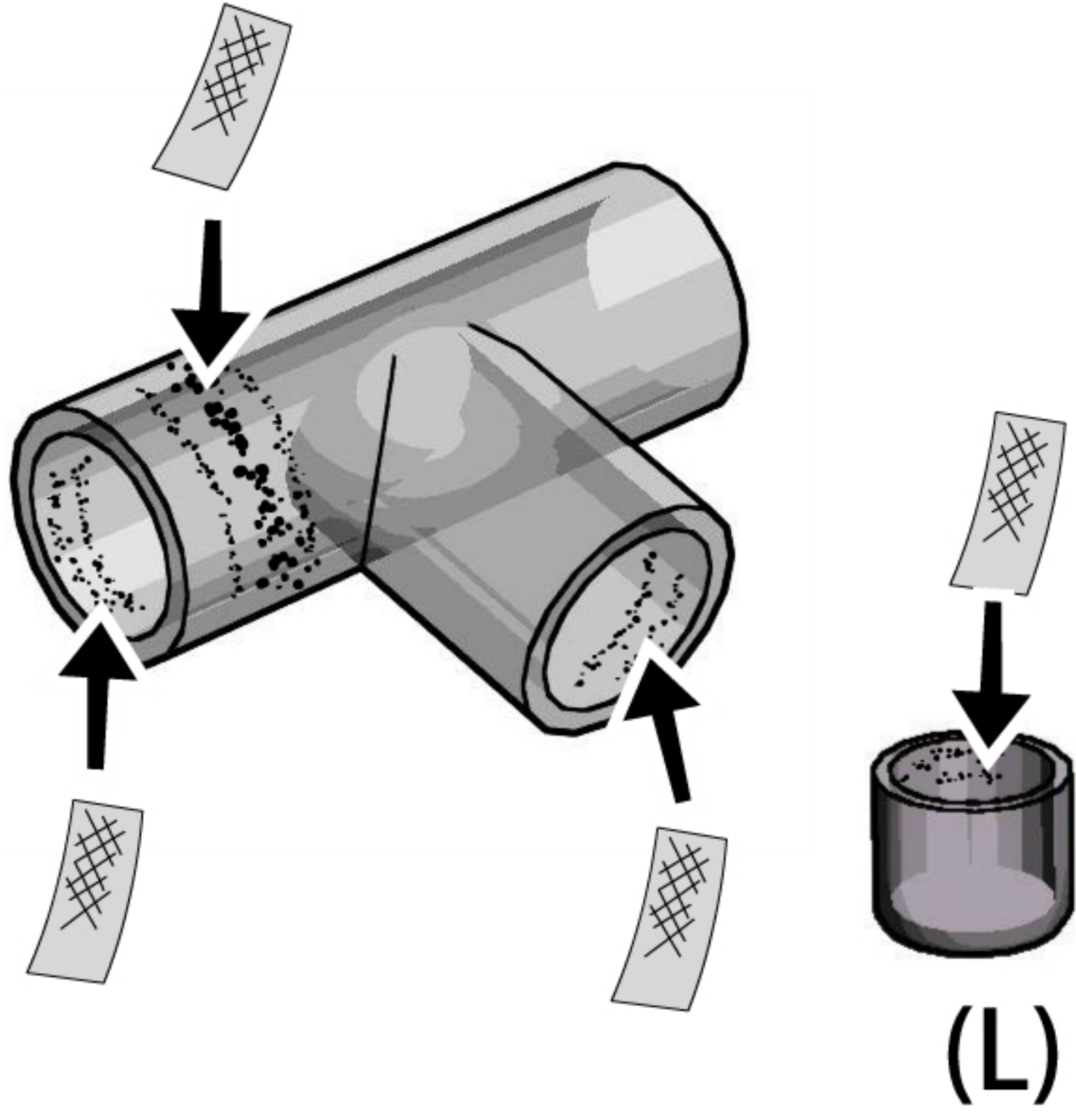
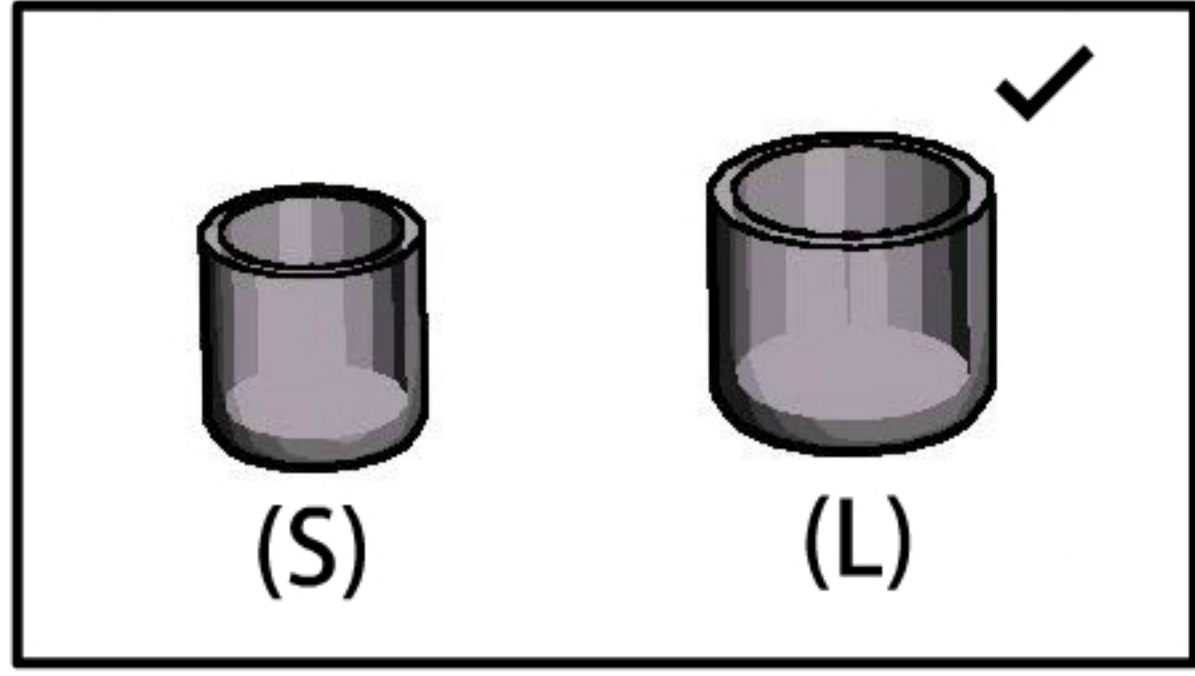

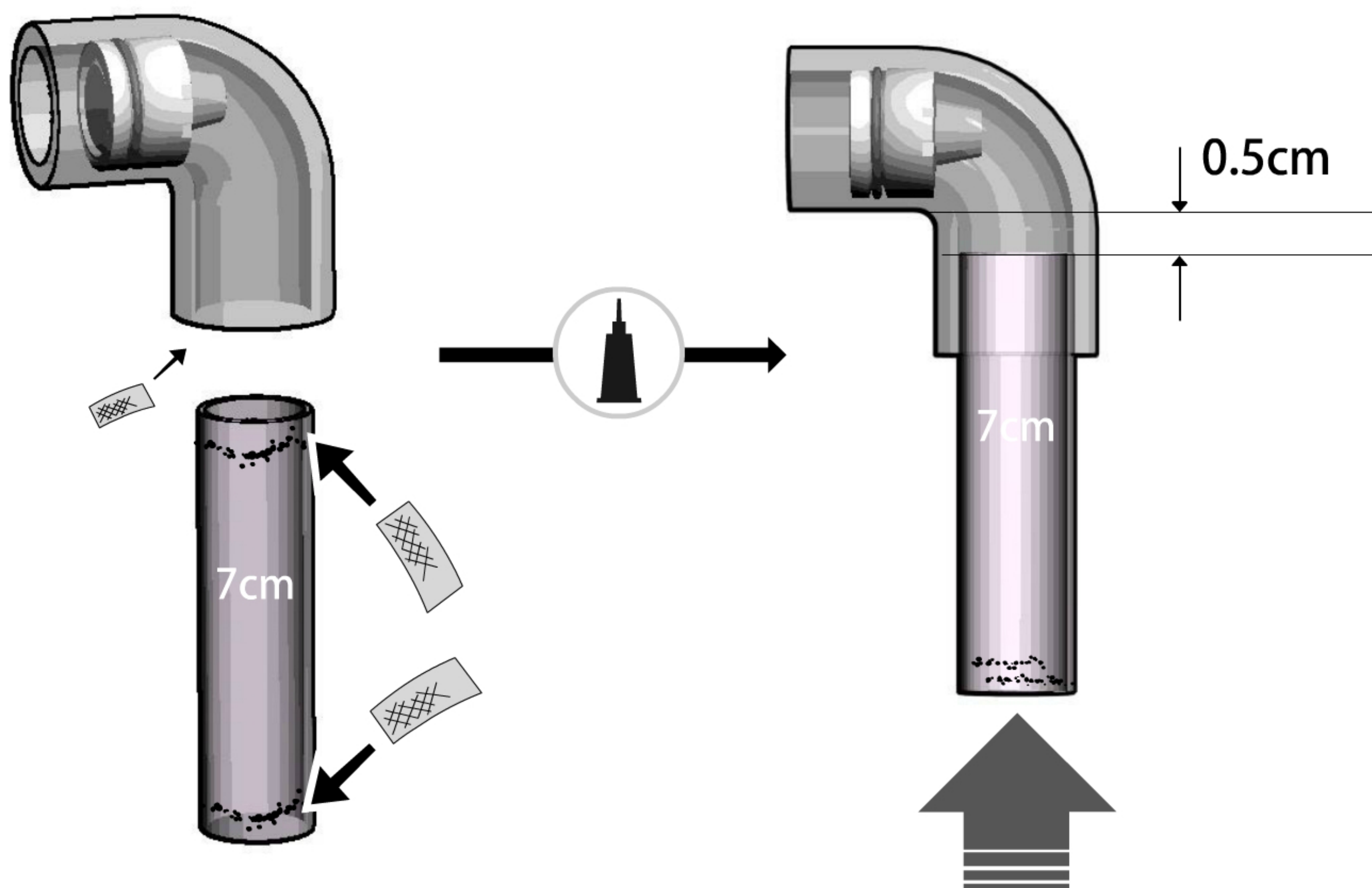
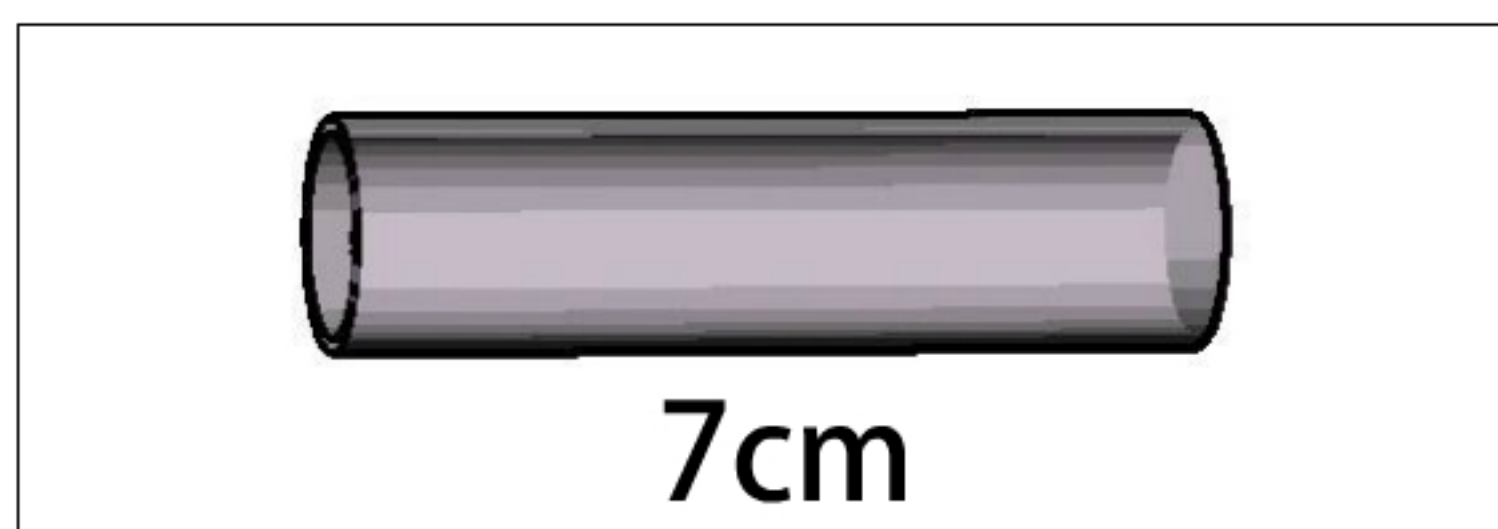
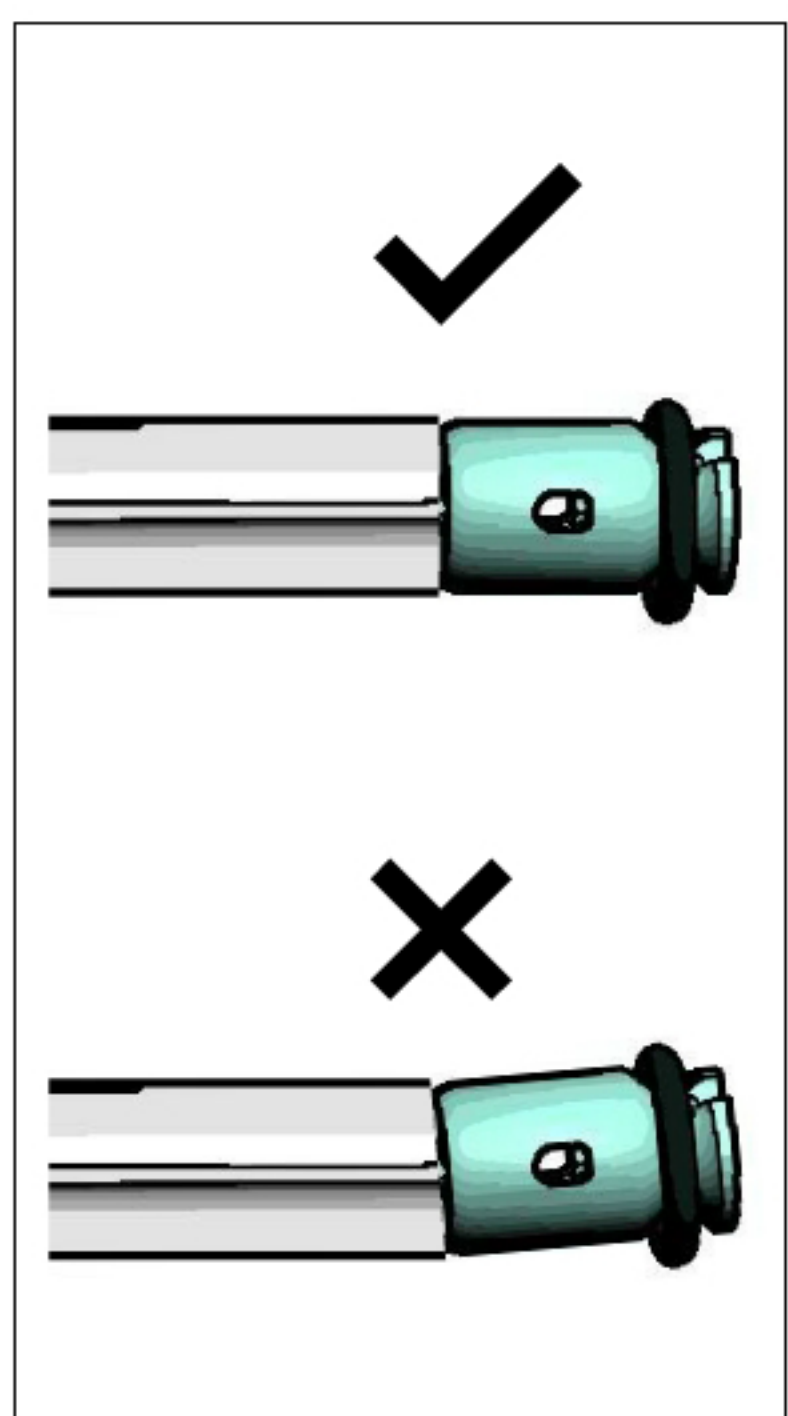
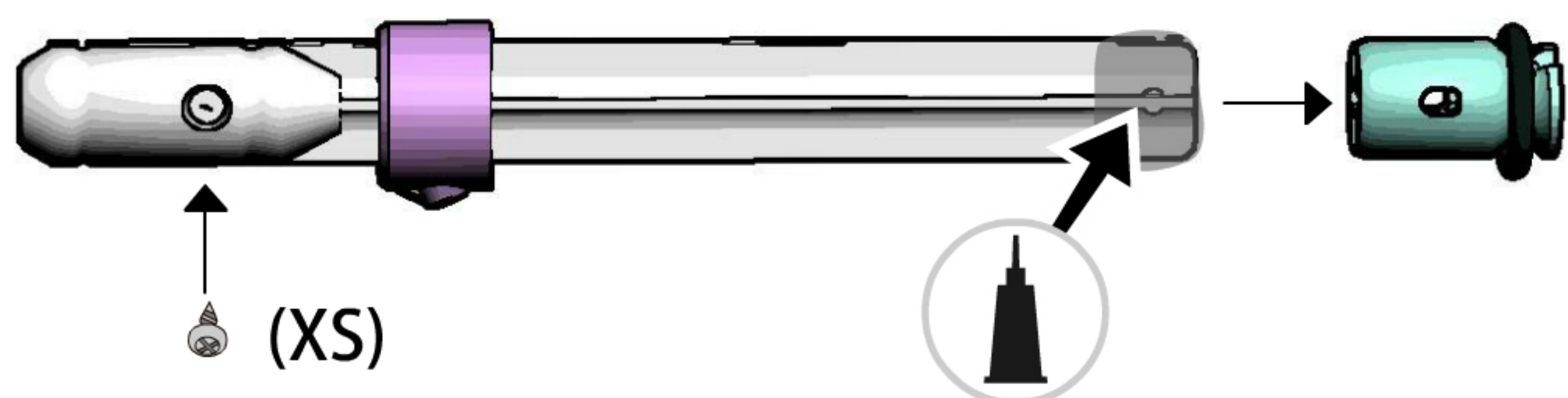
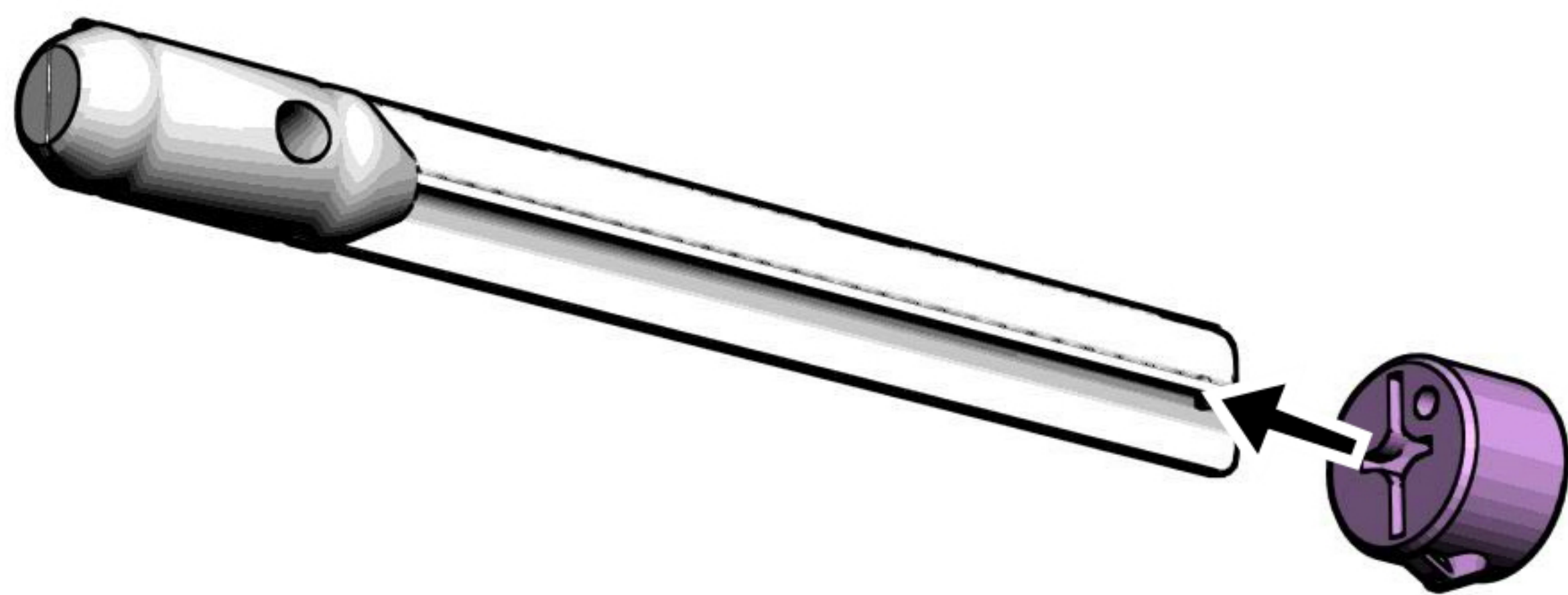



Challenging steps 具有挑戰性的步驟

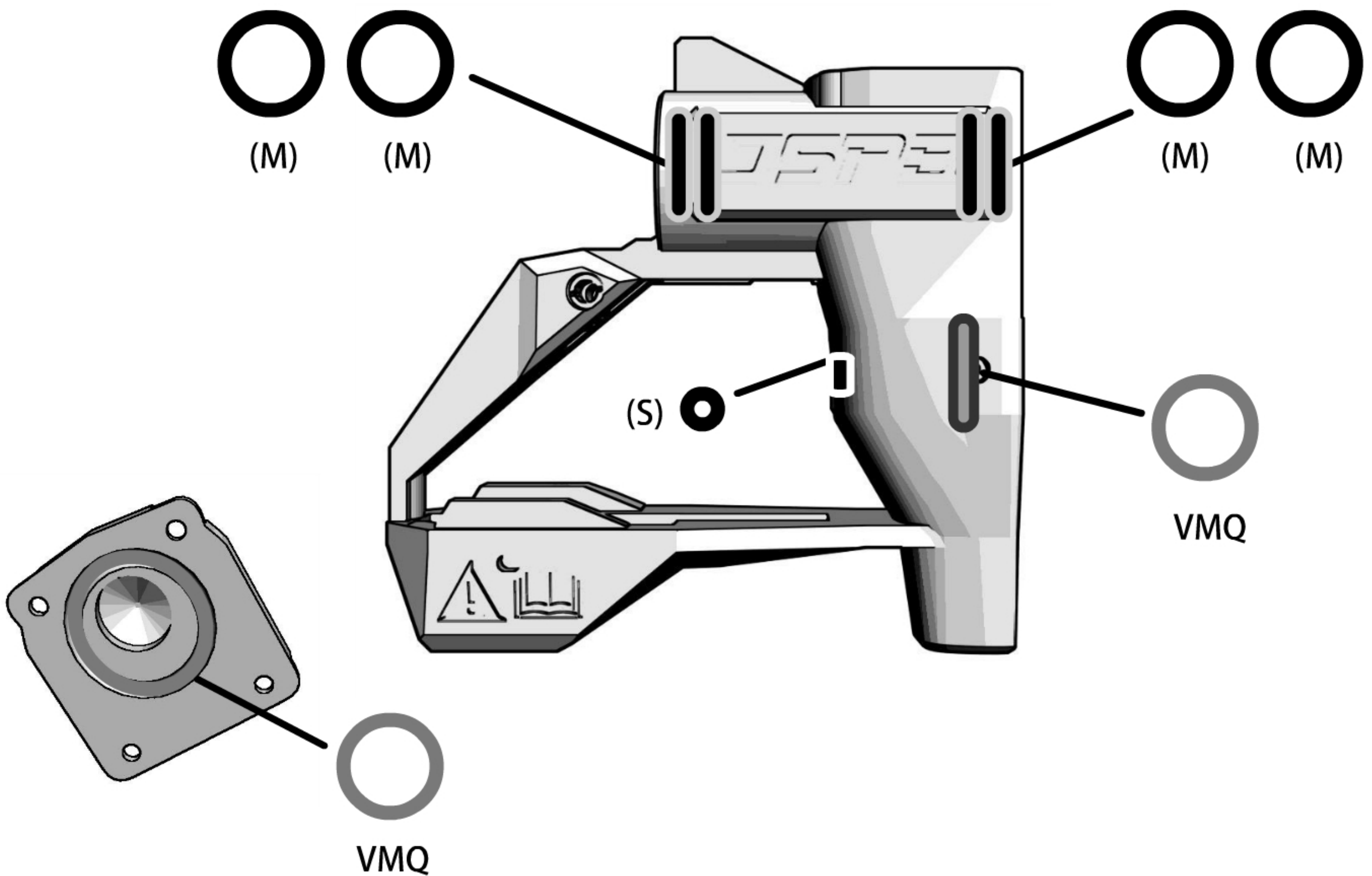
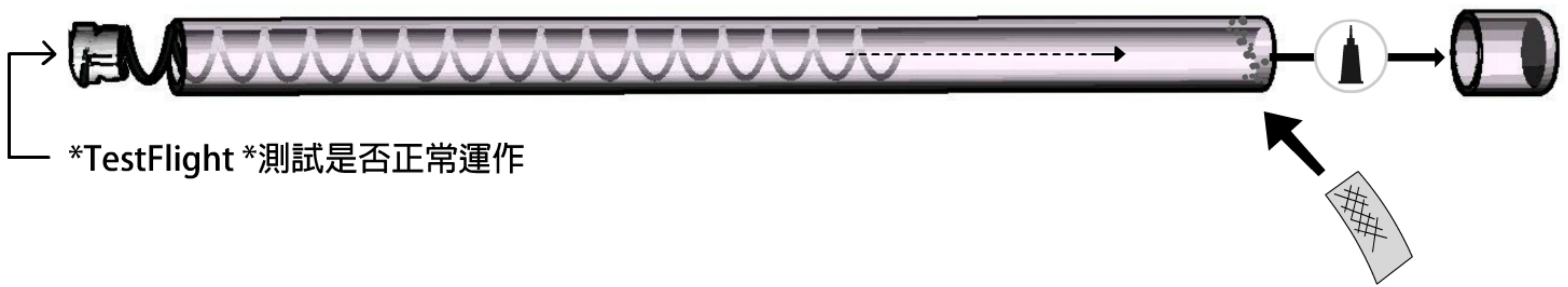
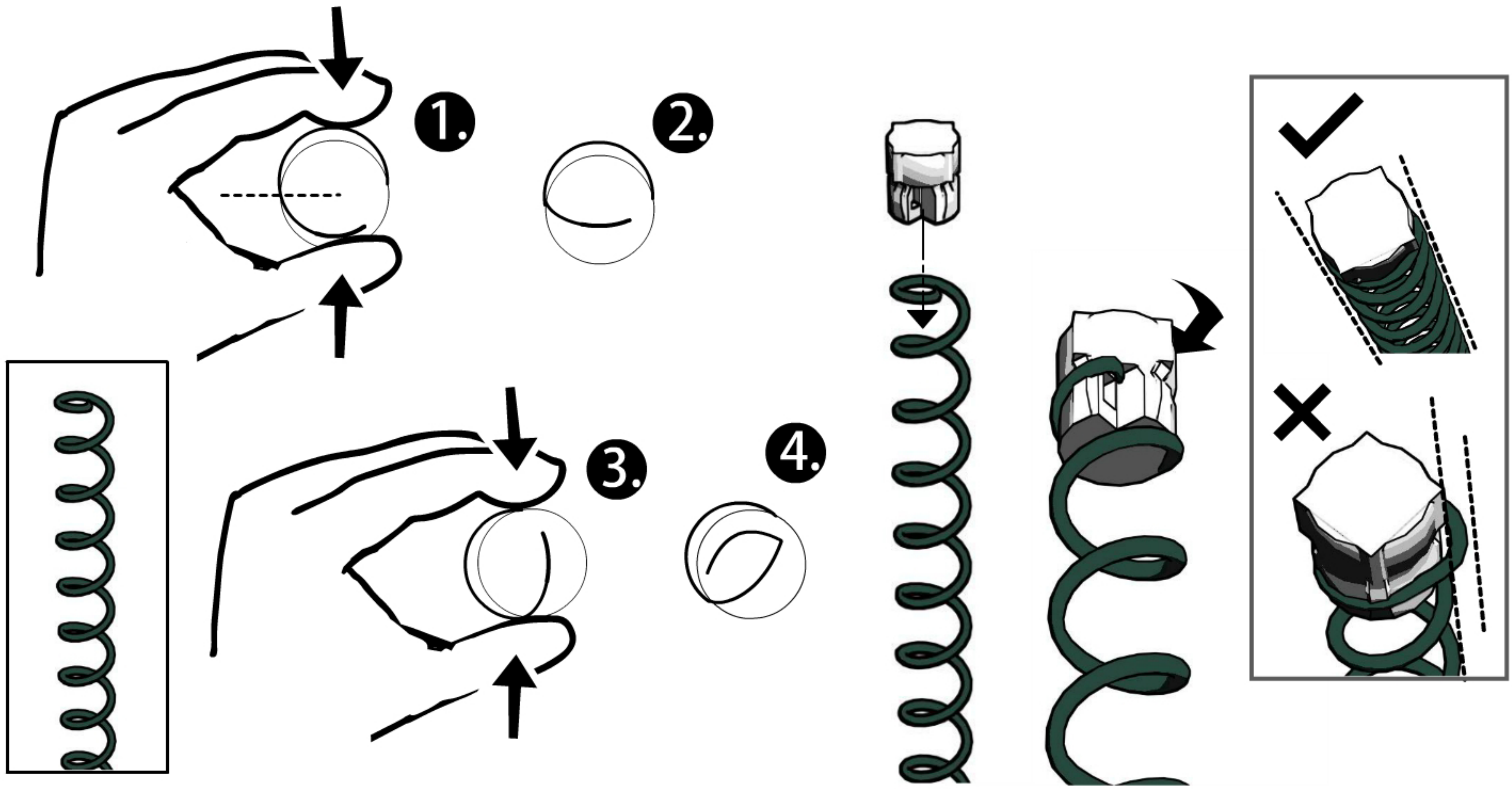

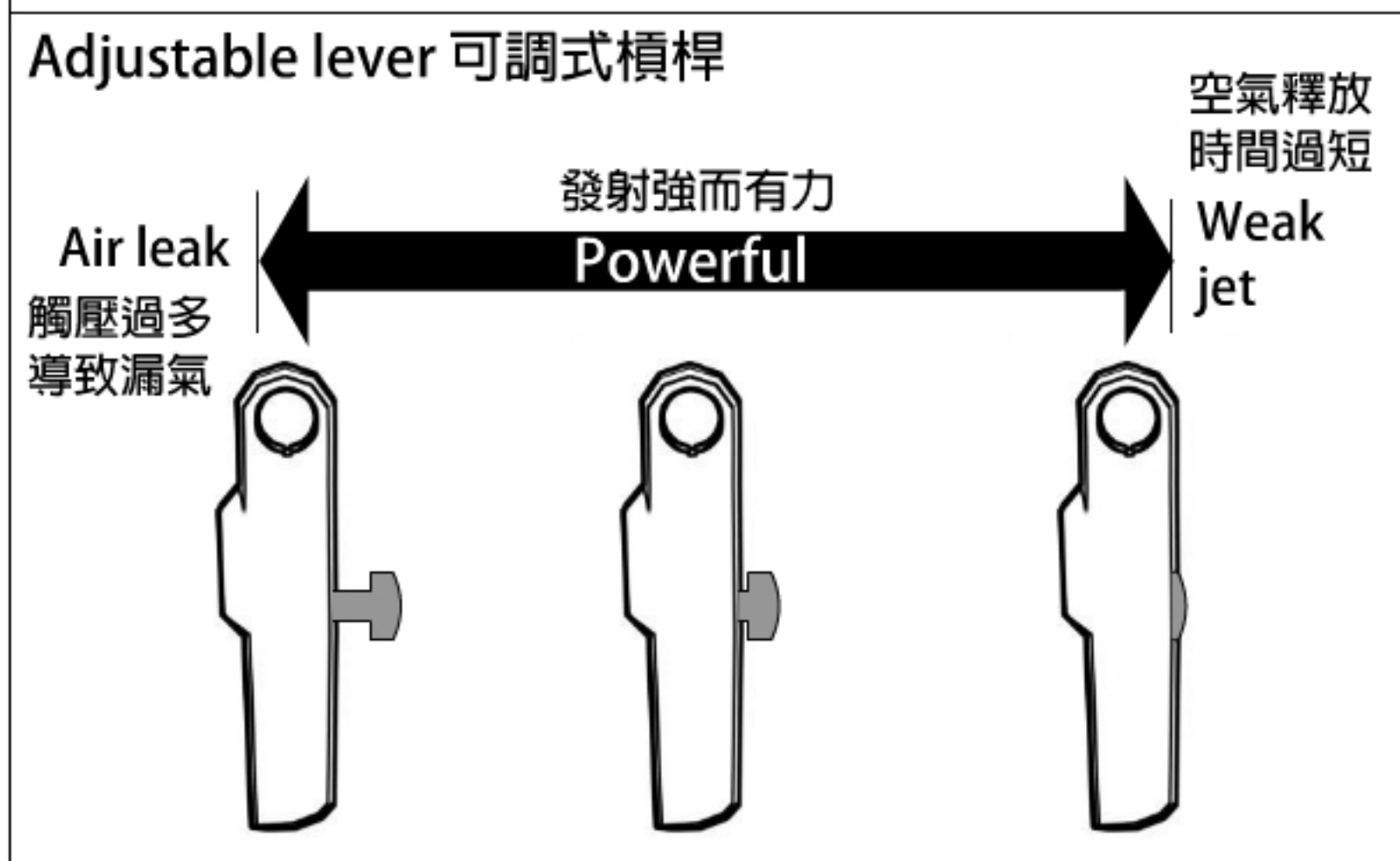
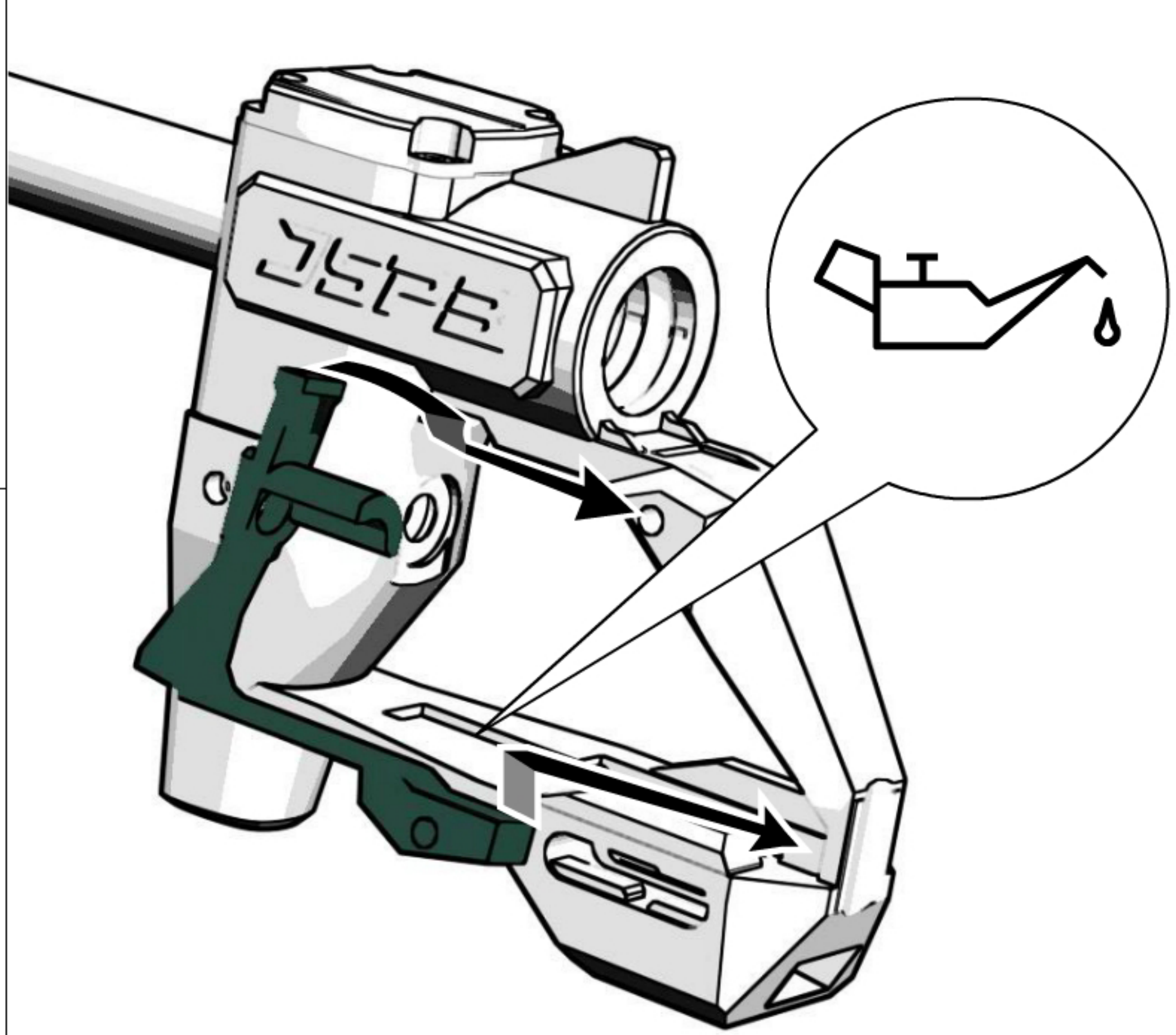
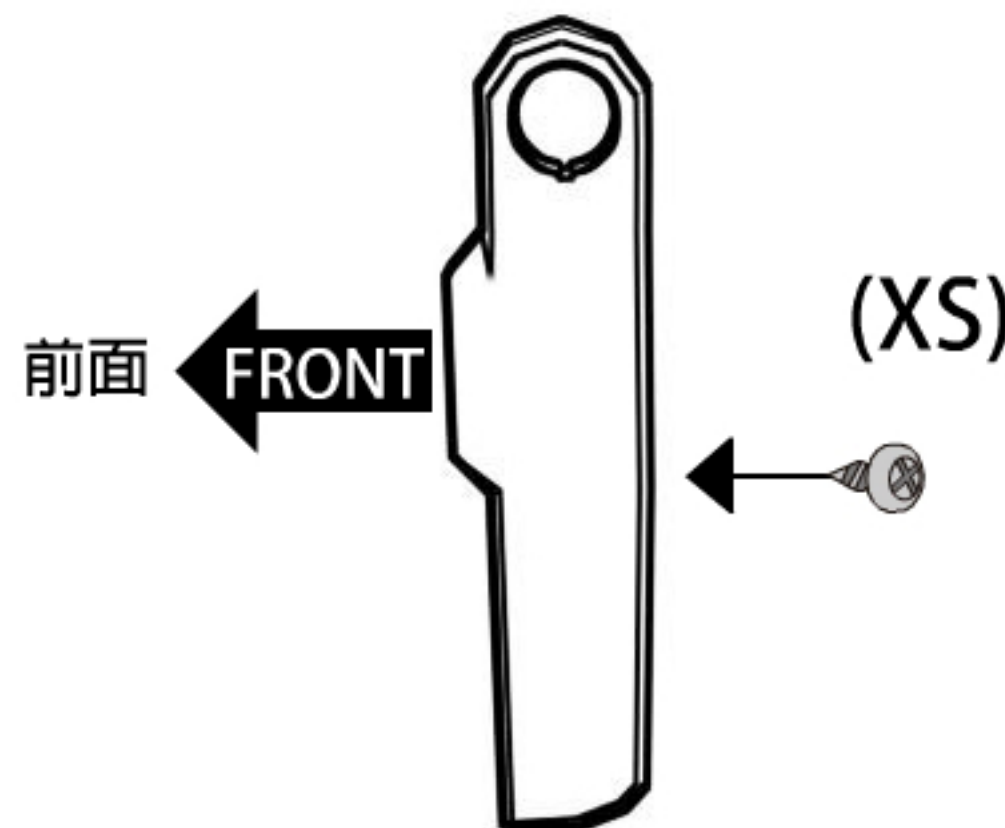
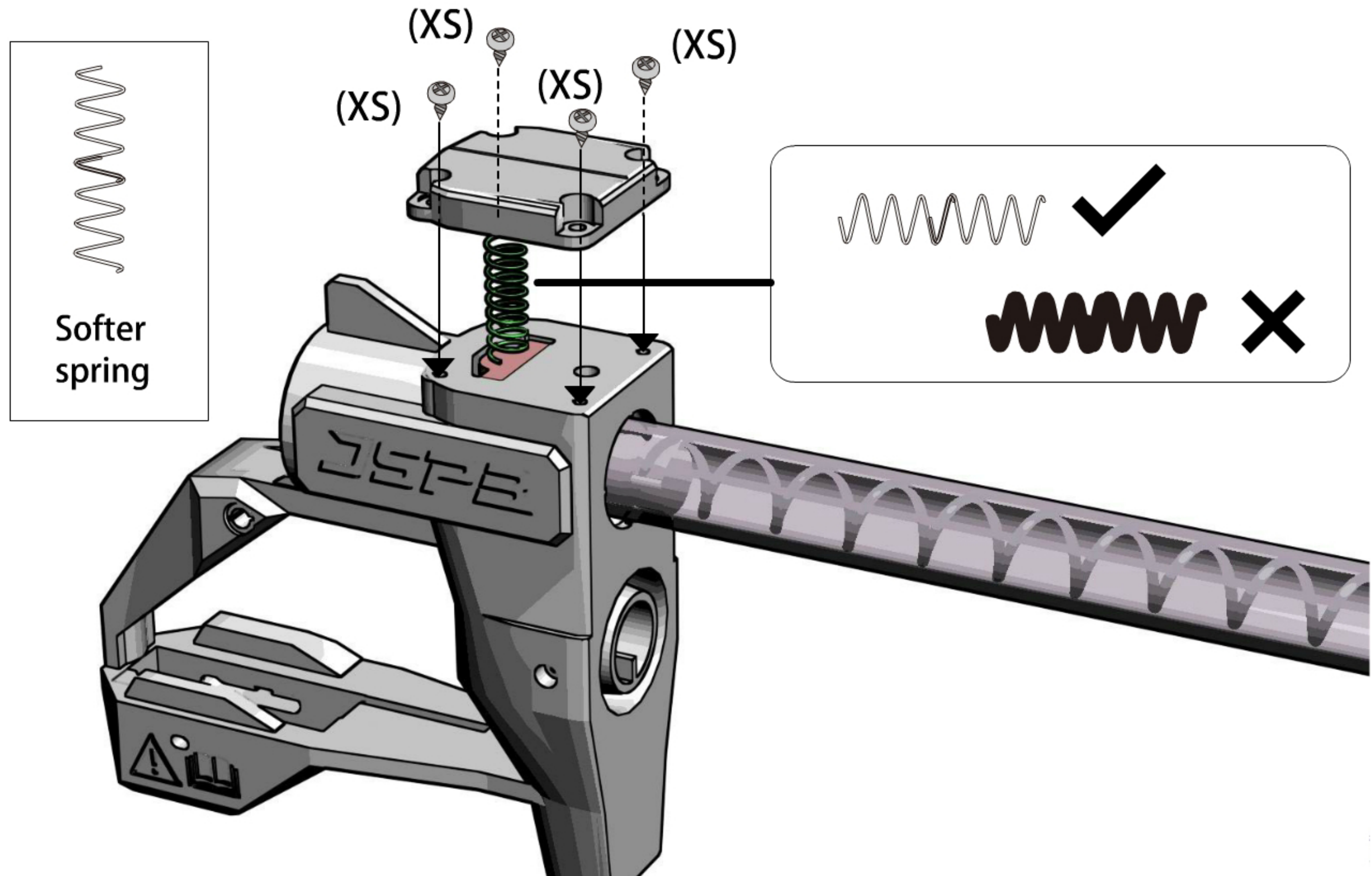
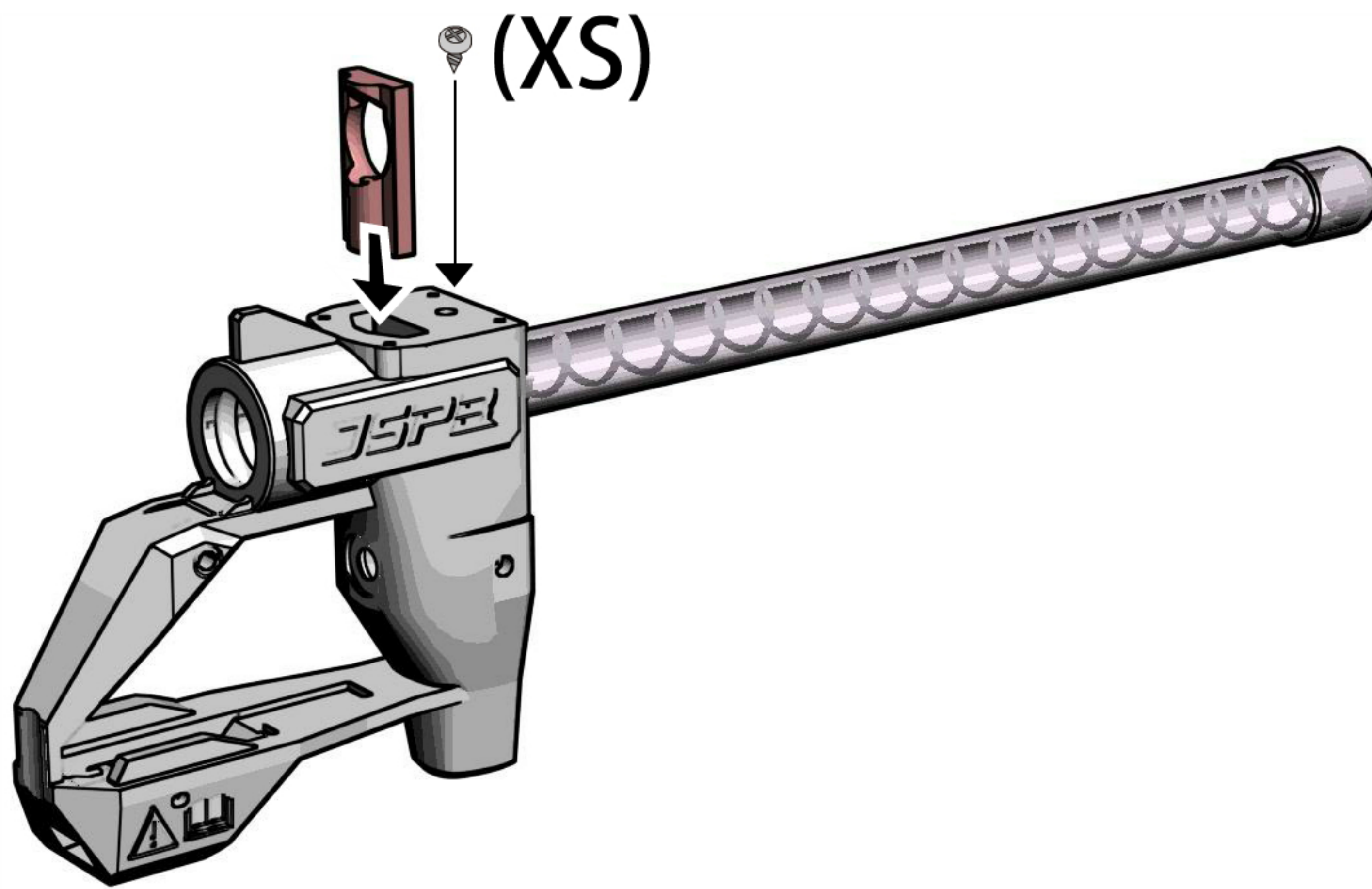

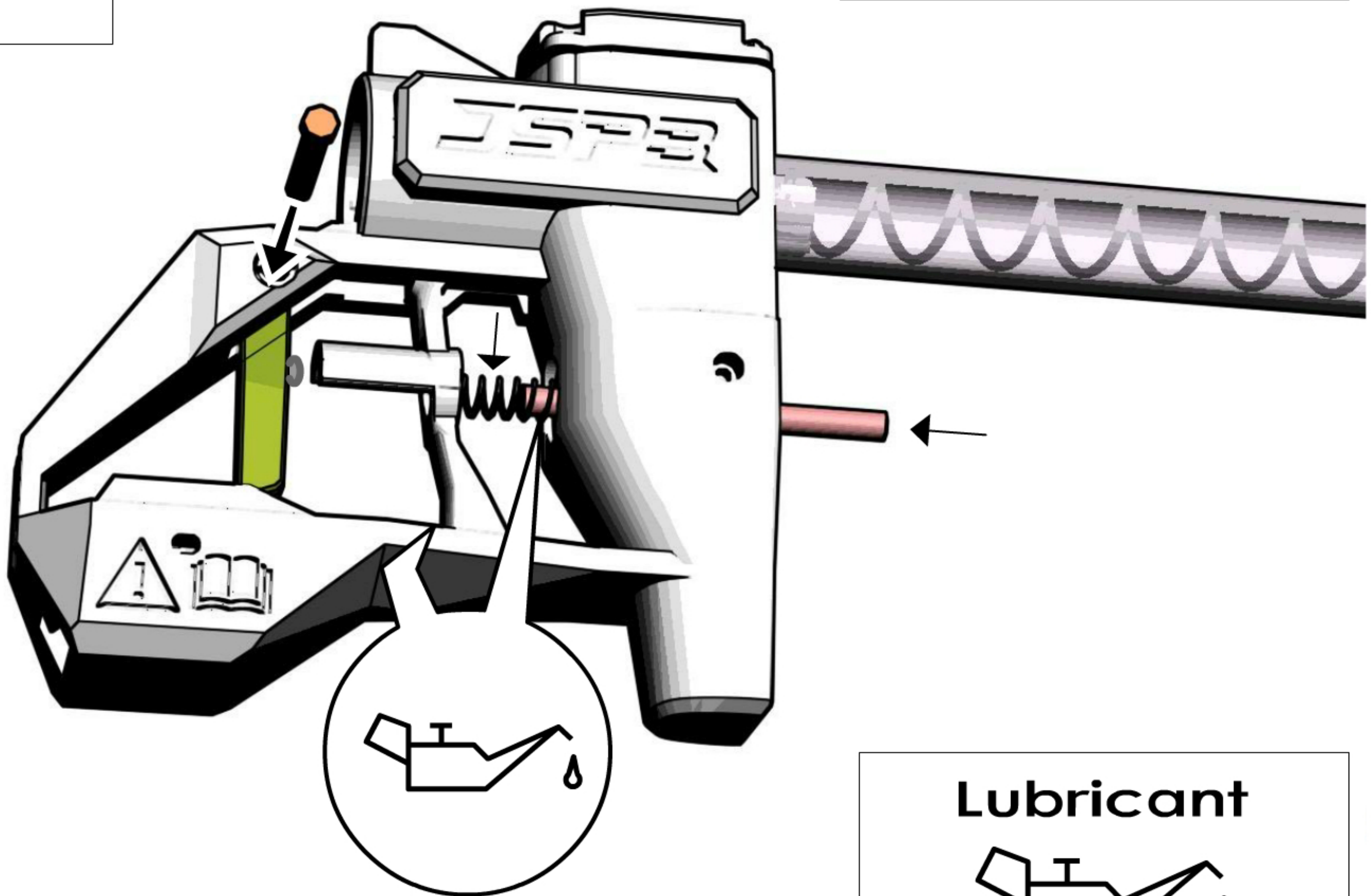
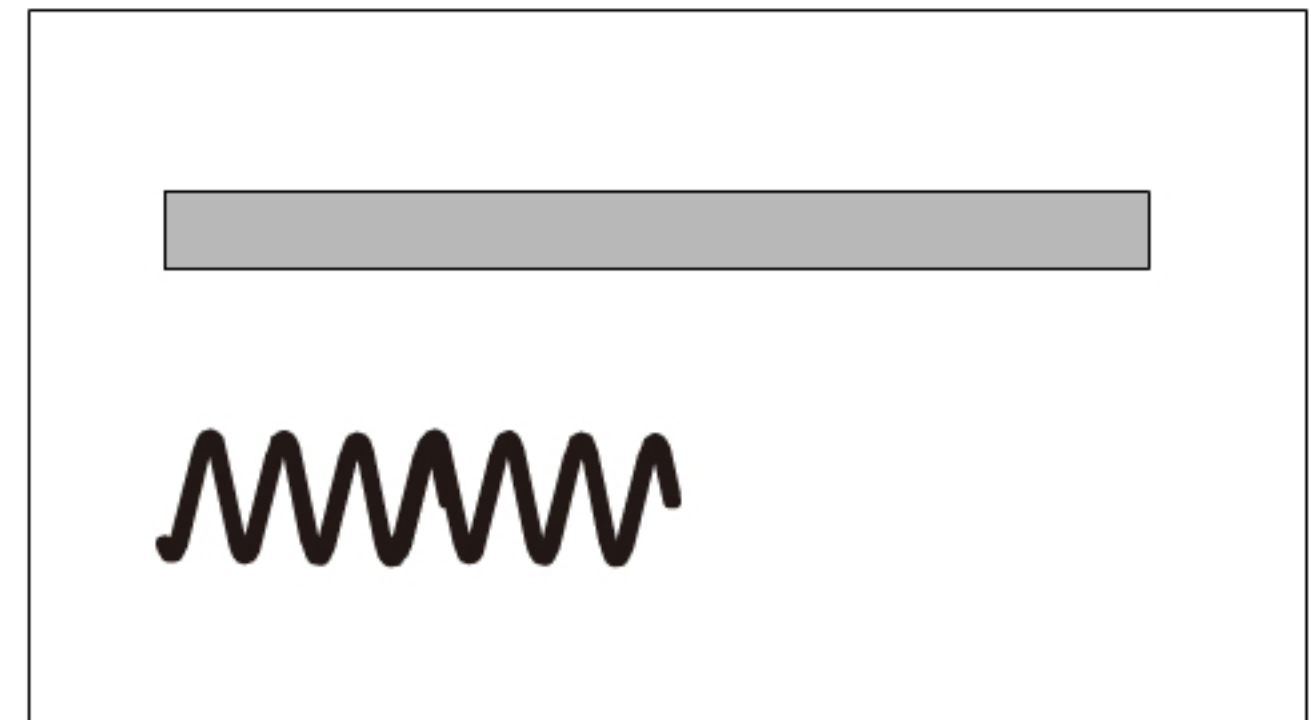
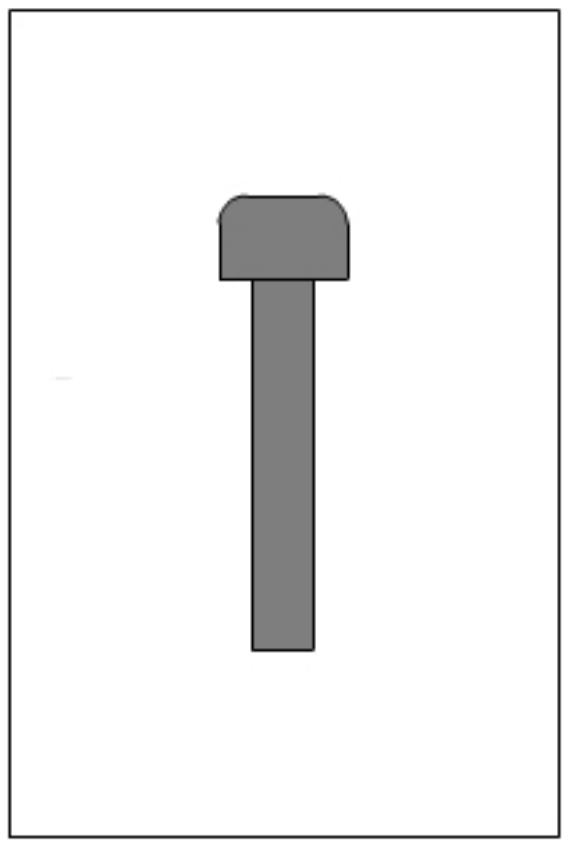
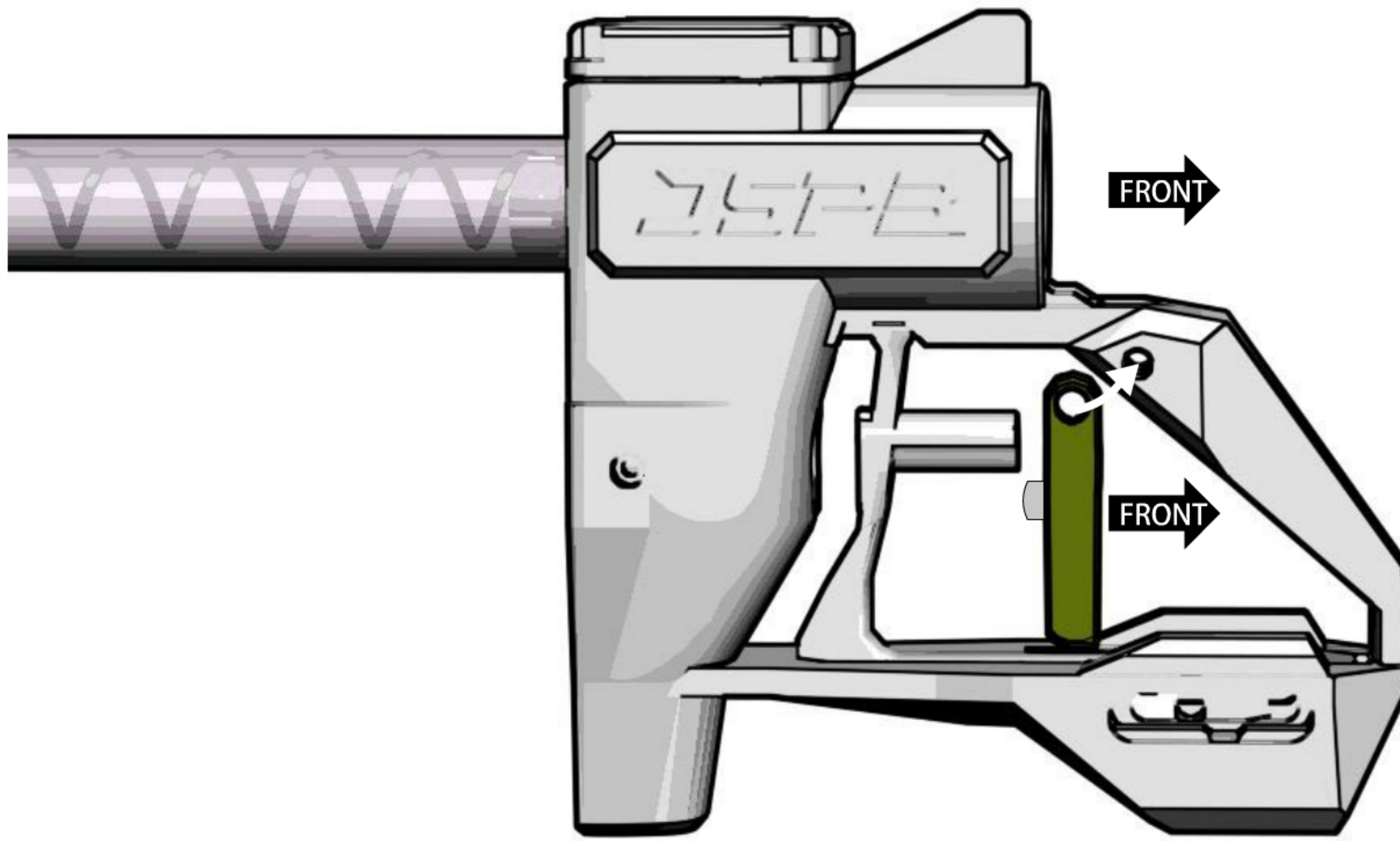

Lubricant

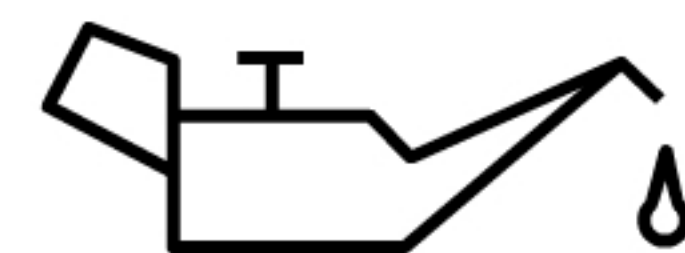

Slicon Oil 1000~10000 CPS

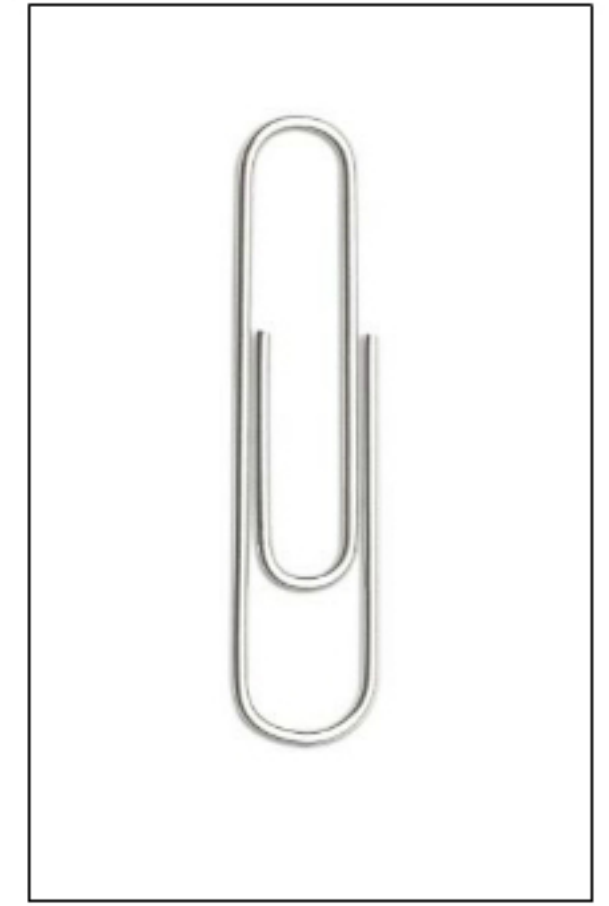
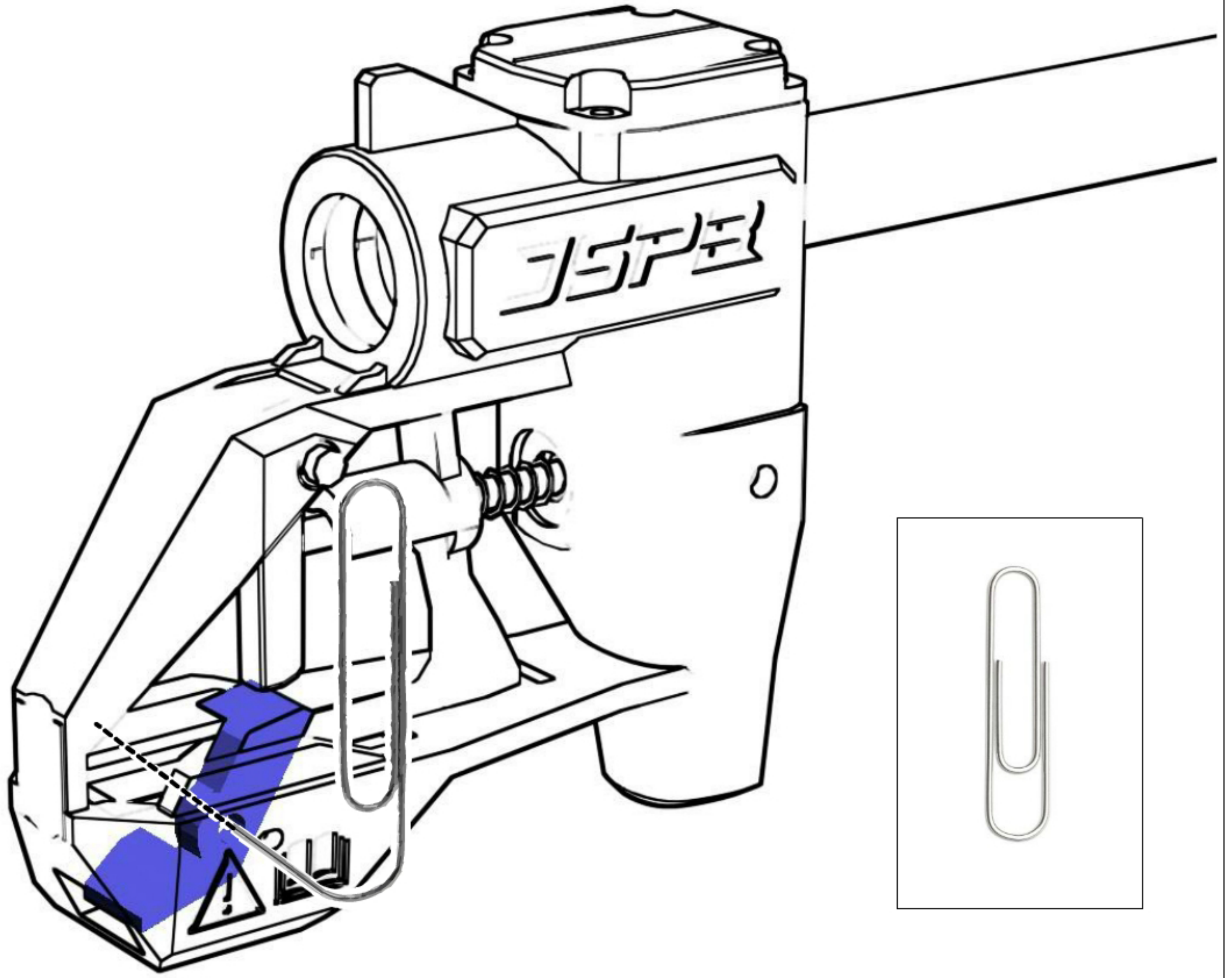
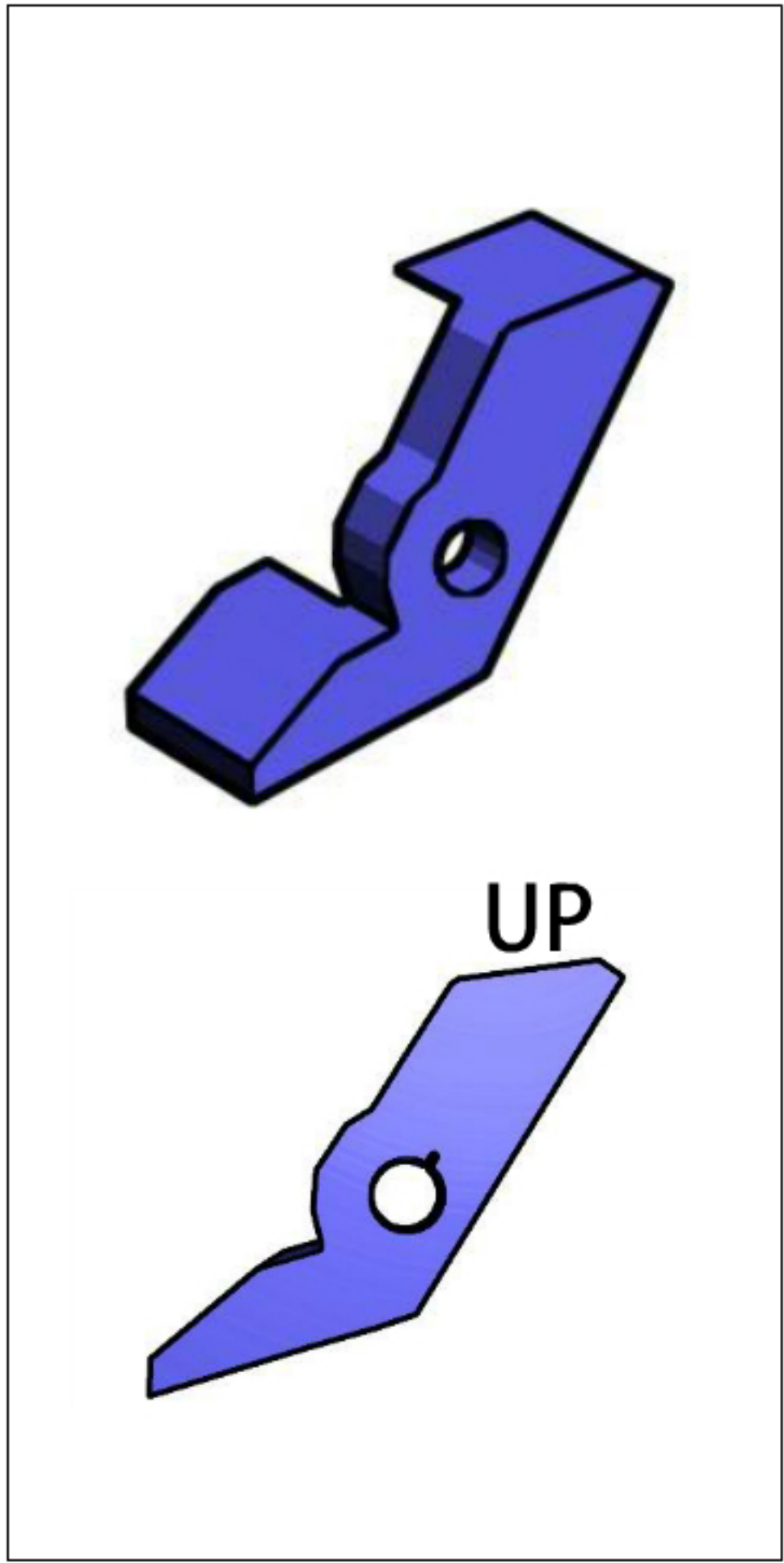

Challenging steps
具有挑戰性的步驟

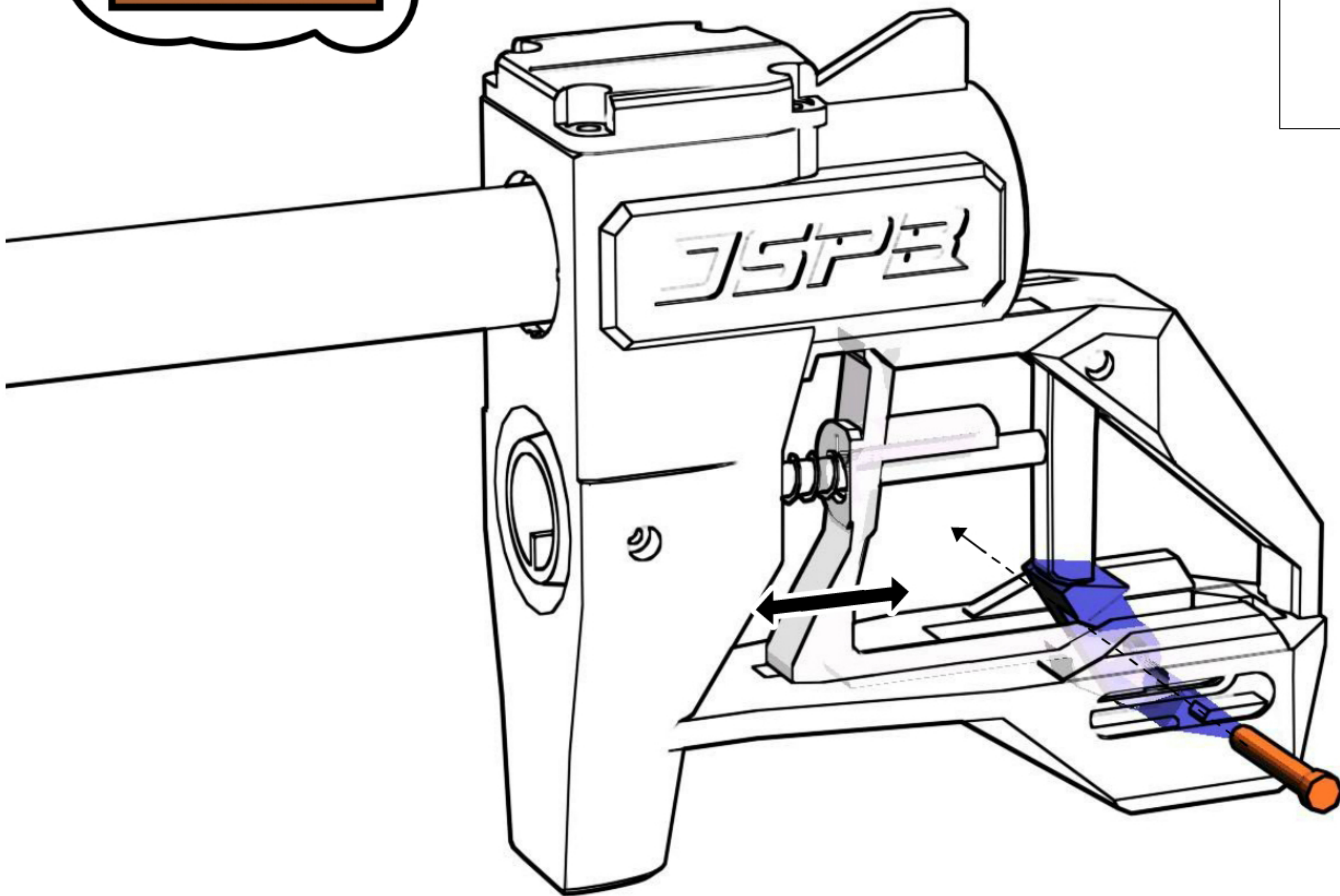
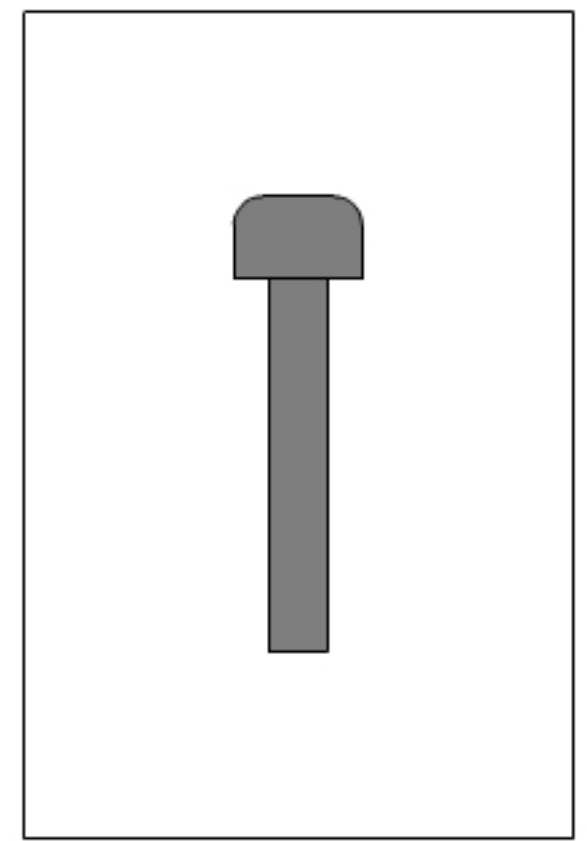



CHECK POINT
檢查點

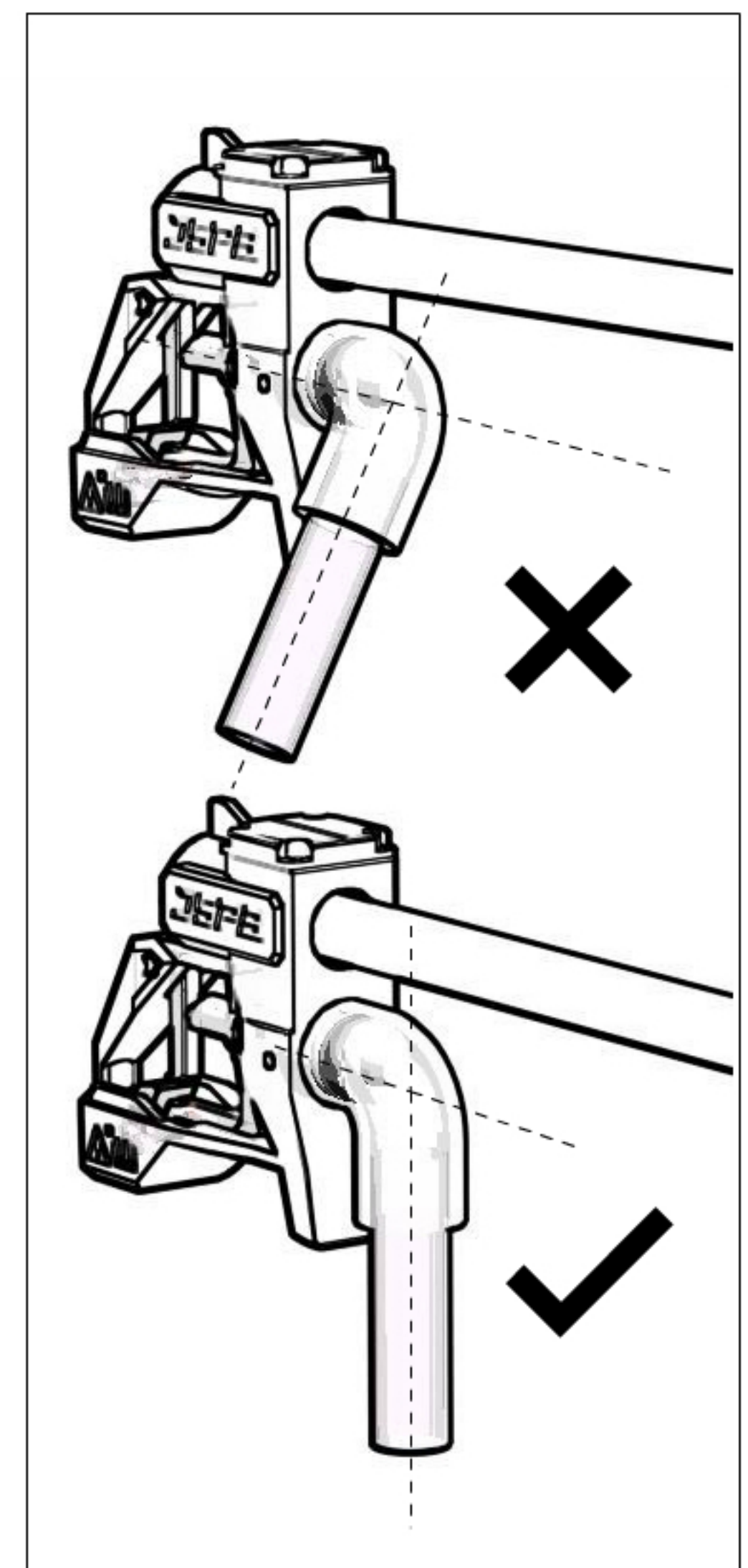
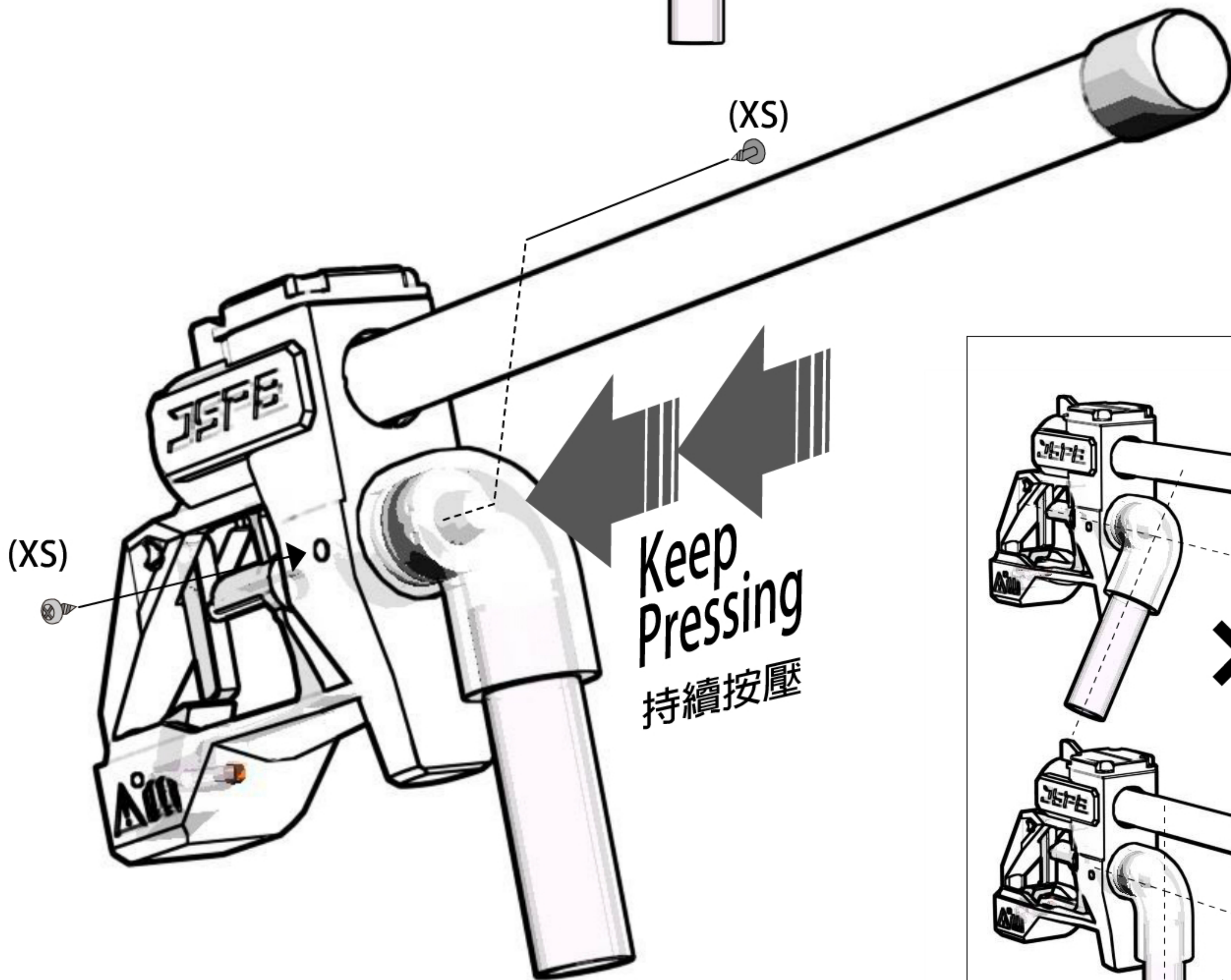
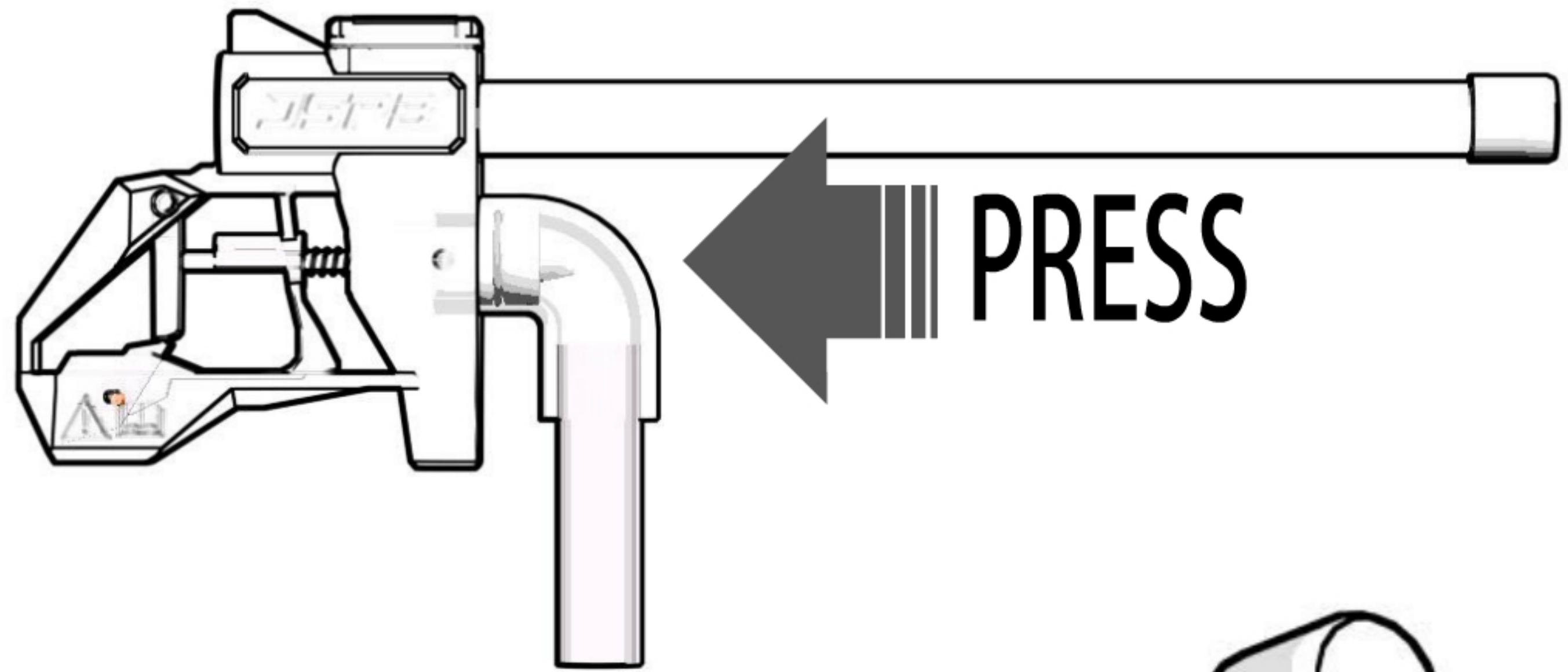
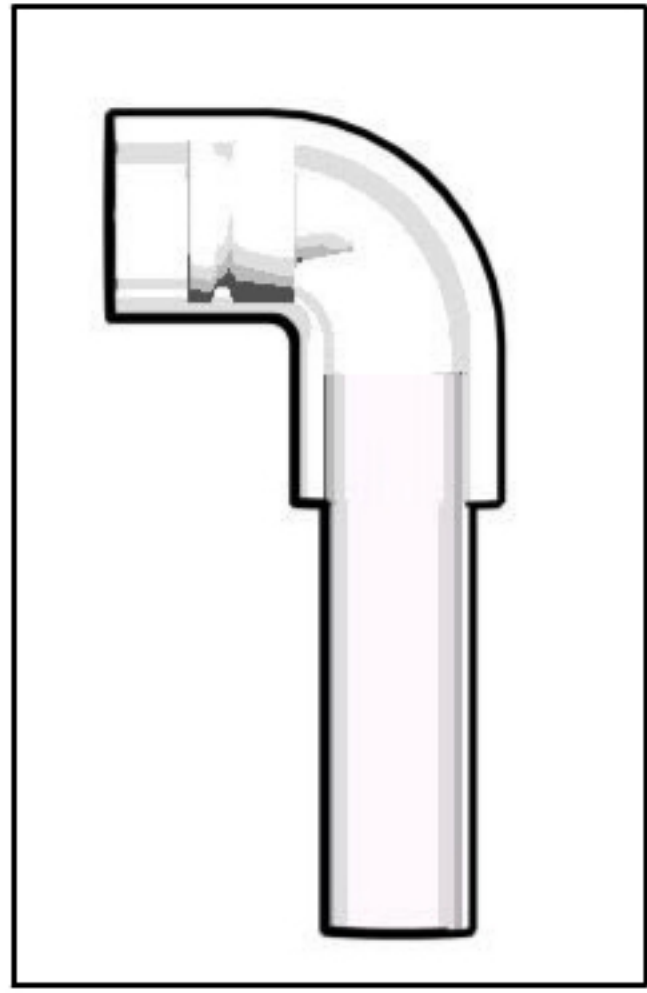
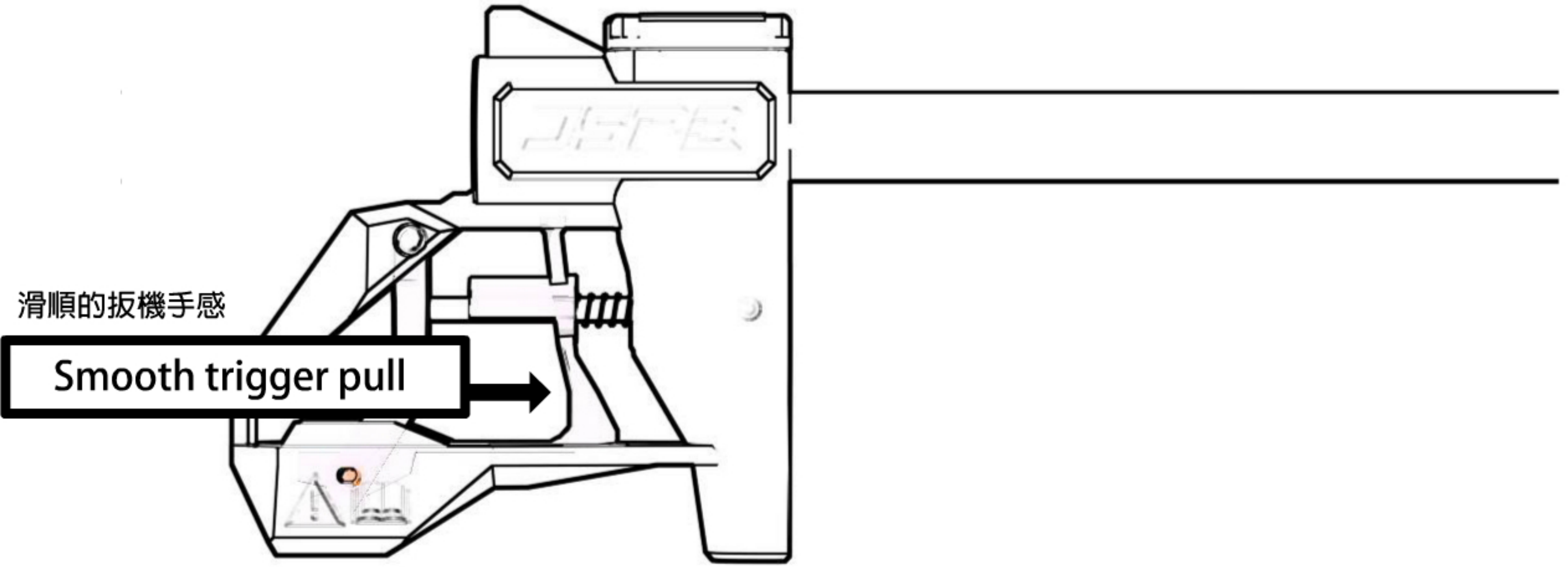

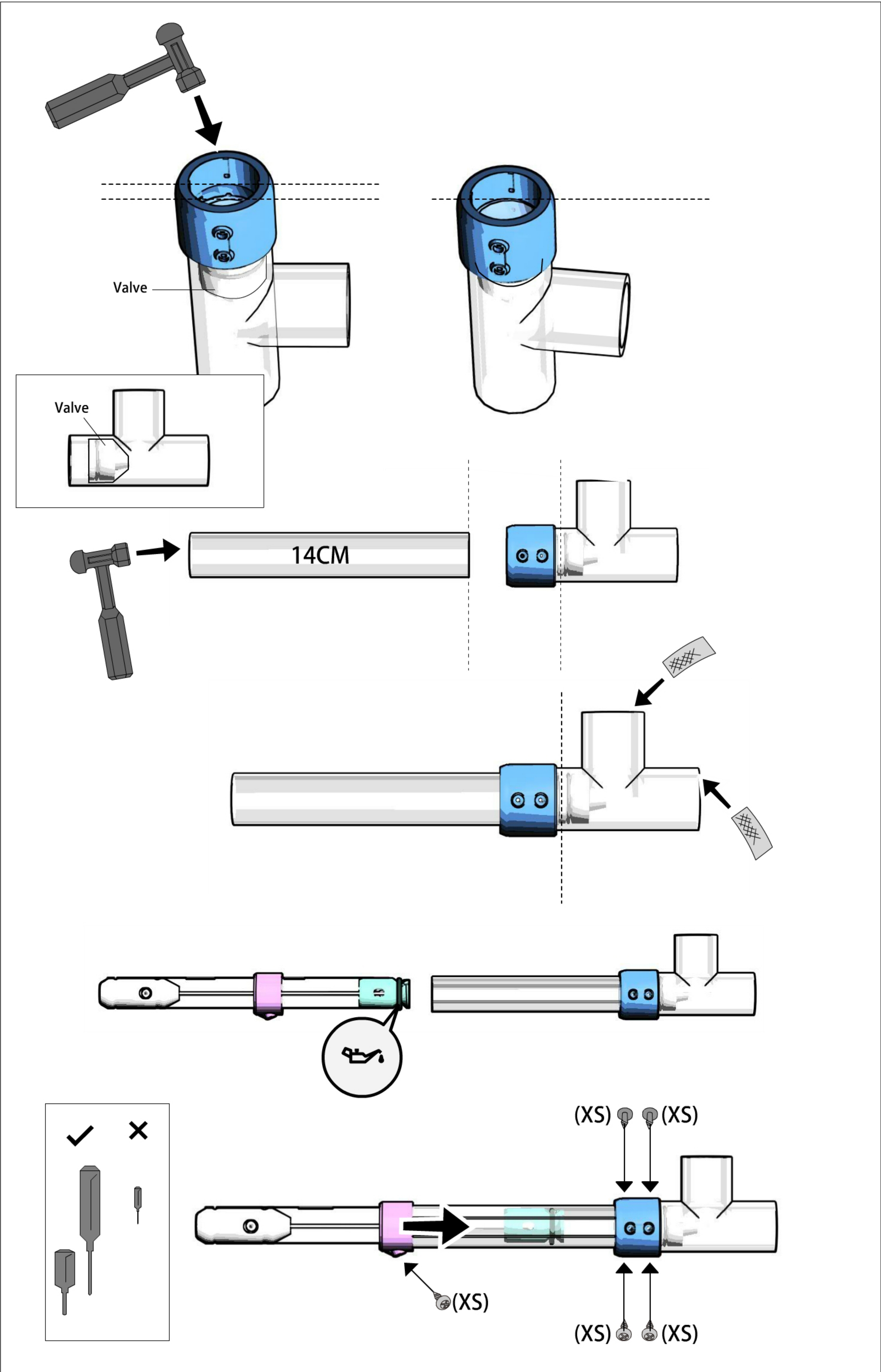

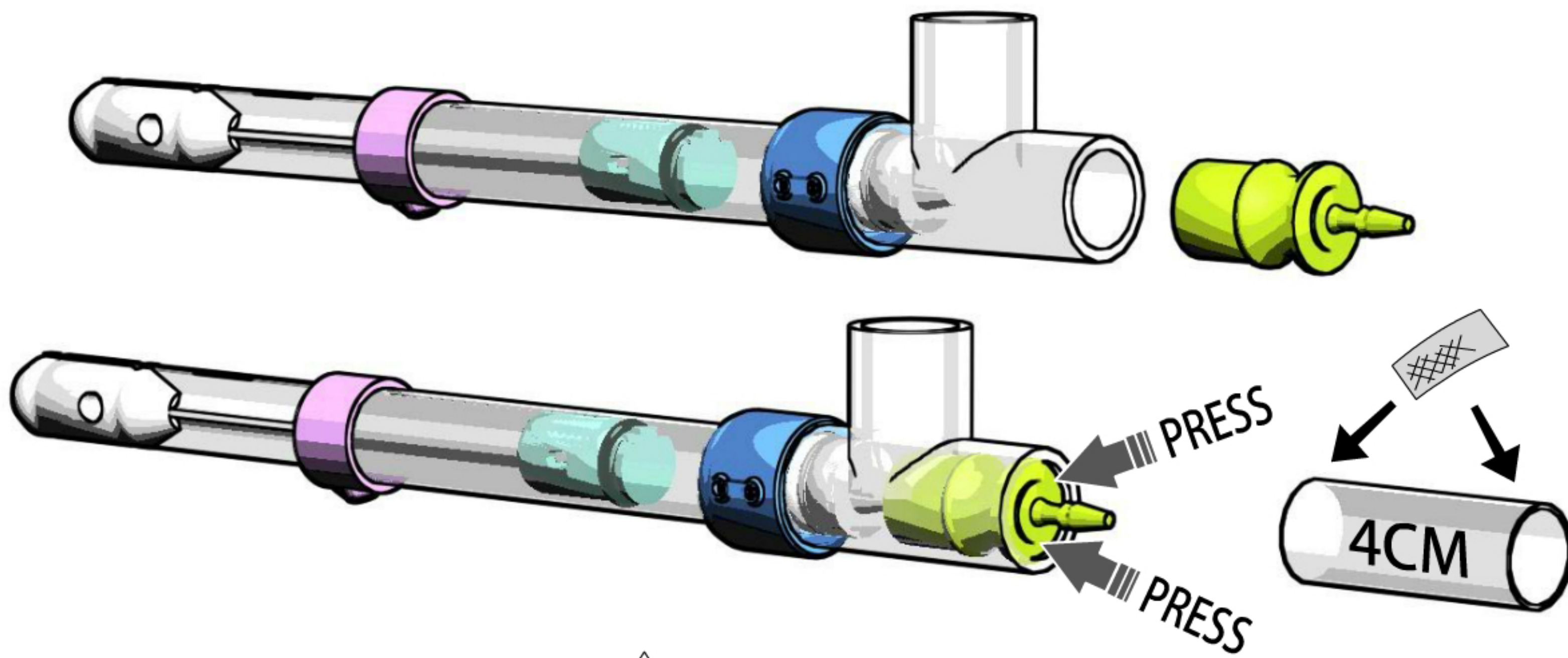

! TO TEST

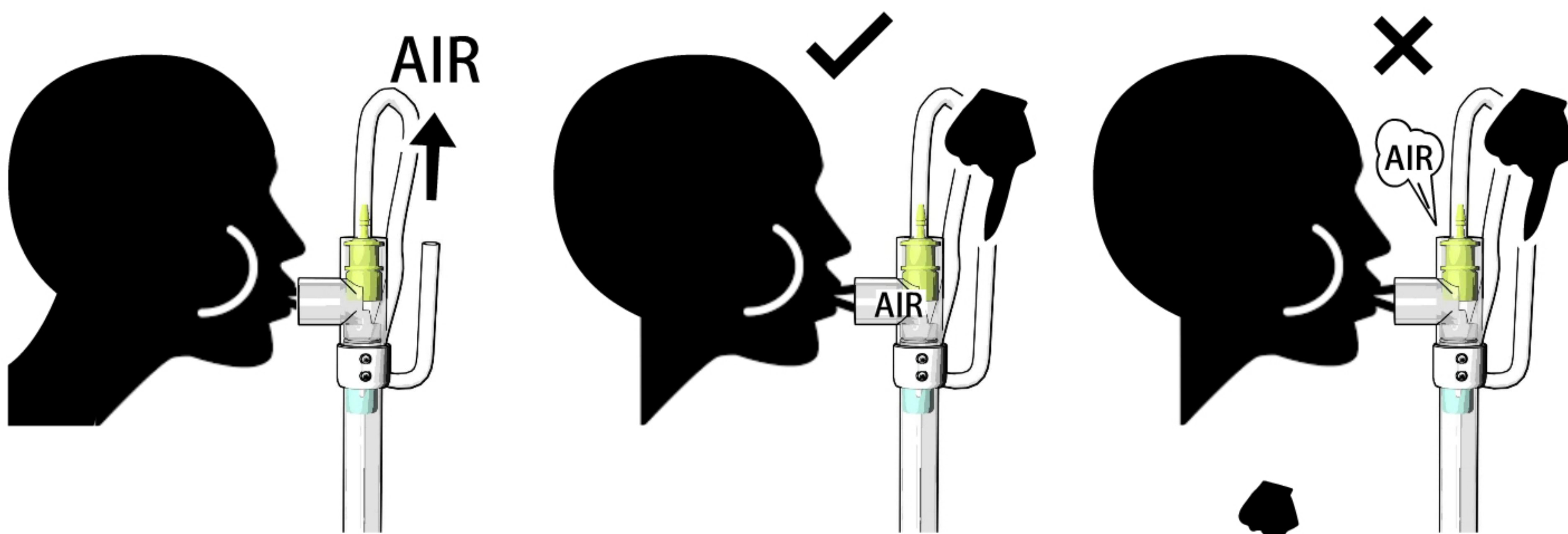

- 1.Reinstall the parts and change the position.
- 2.If a part breaks, it can be repaired with glue.
- 3.Large gaps can be filled with glue.

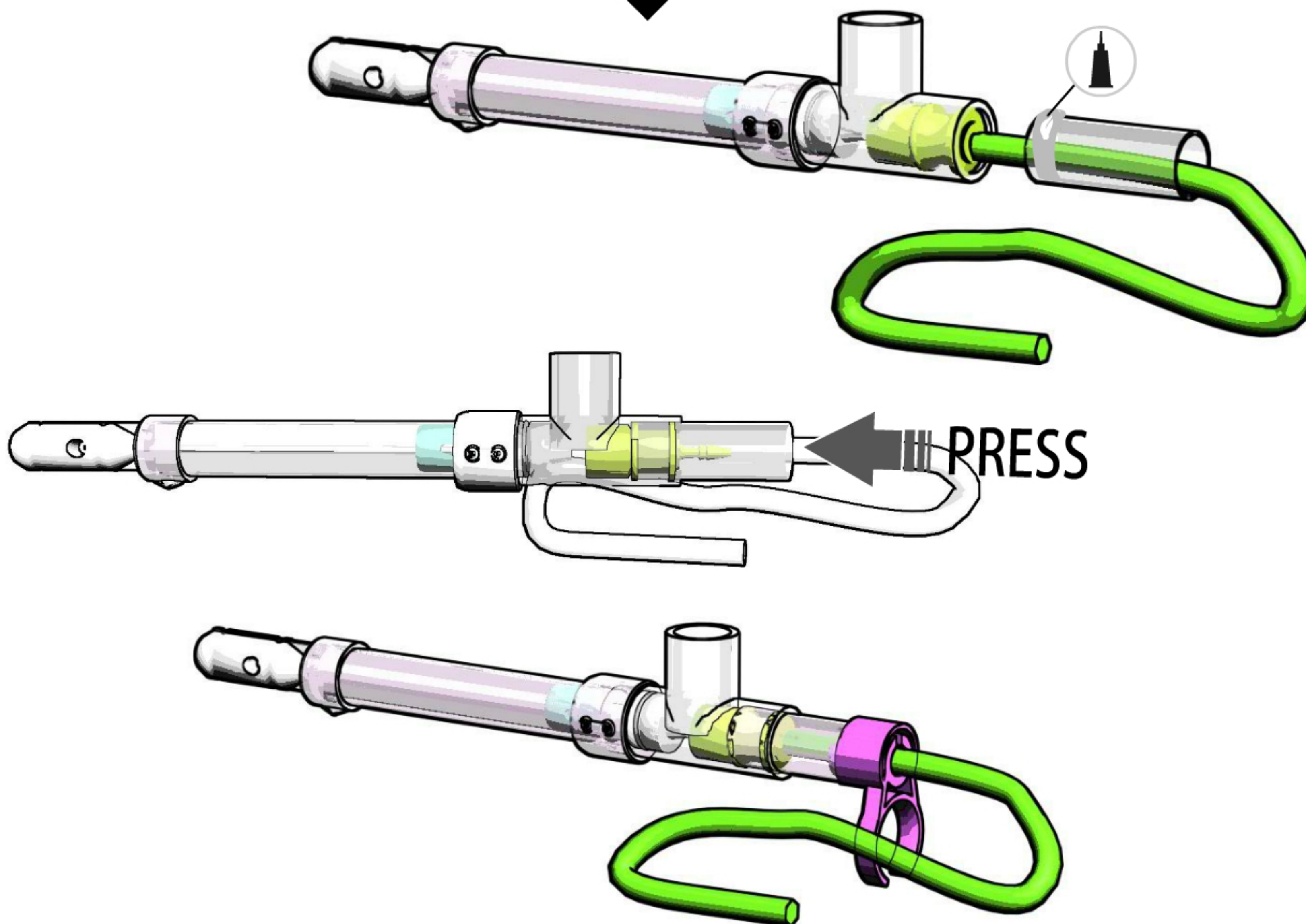

AIR FUSE (Consumables) 氣壓保險絲(消耗品)

LOW-Pressure



100FPS

OR



HI-POWER

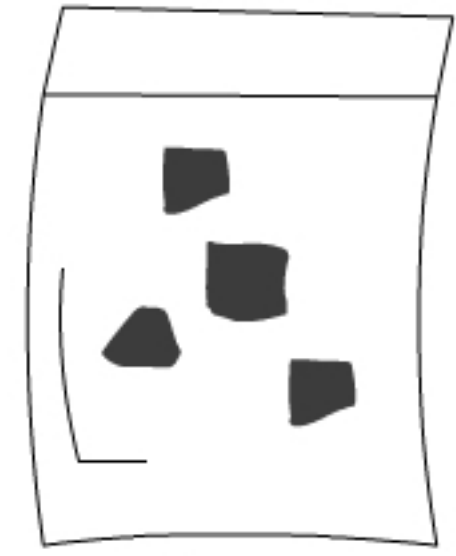
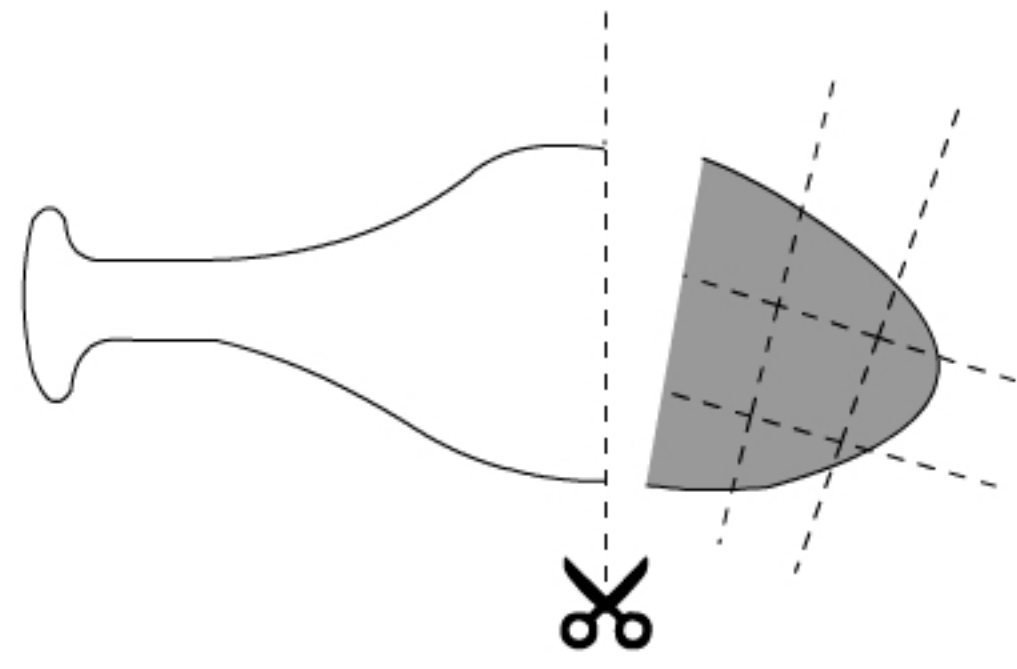

Carry pack

to-go

A small piece of plastic bag



Silicone grease or Vaseline



SEAL

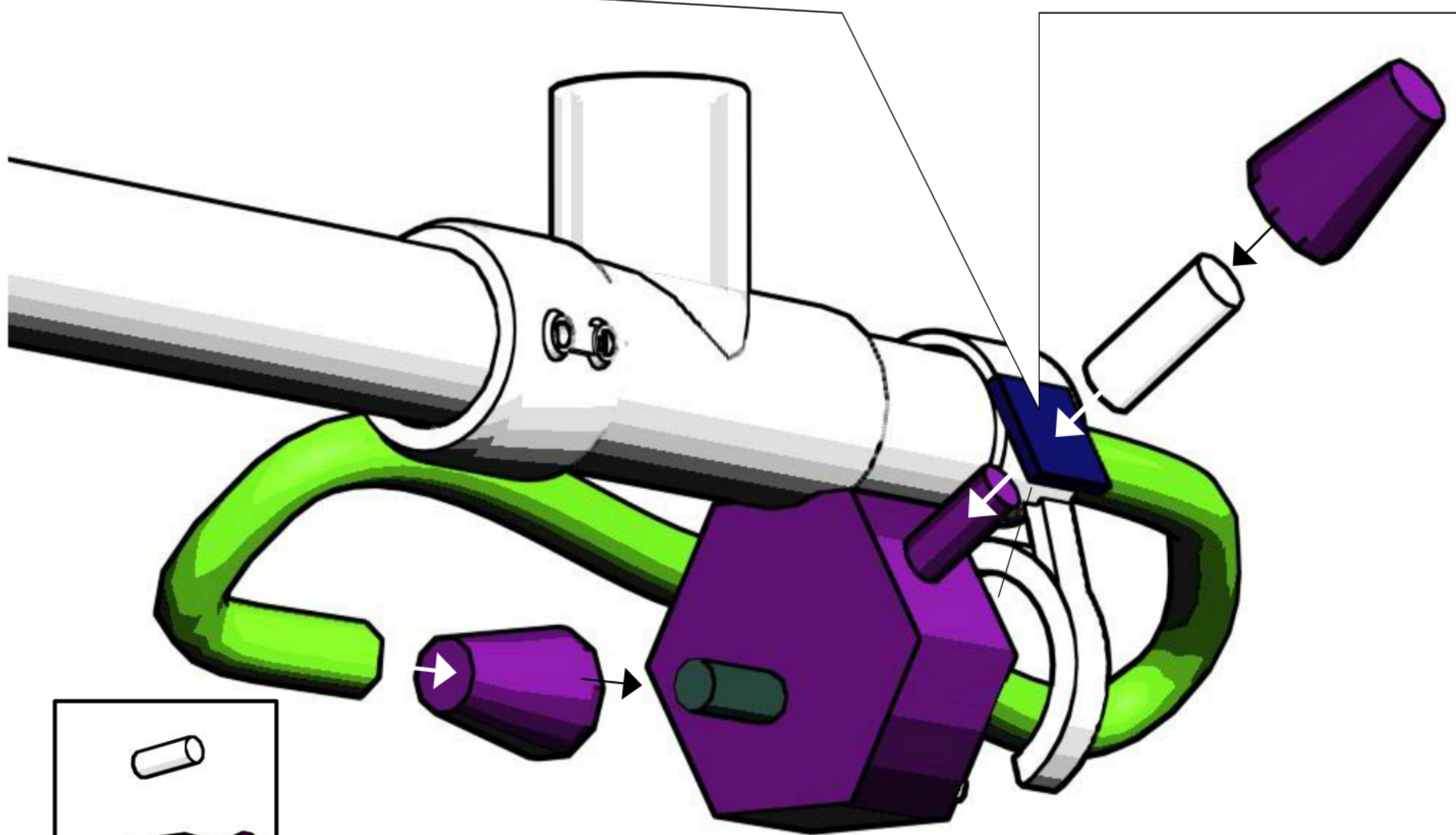

SODA BOTTLE

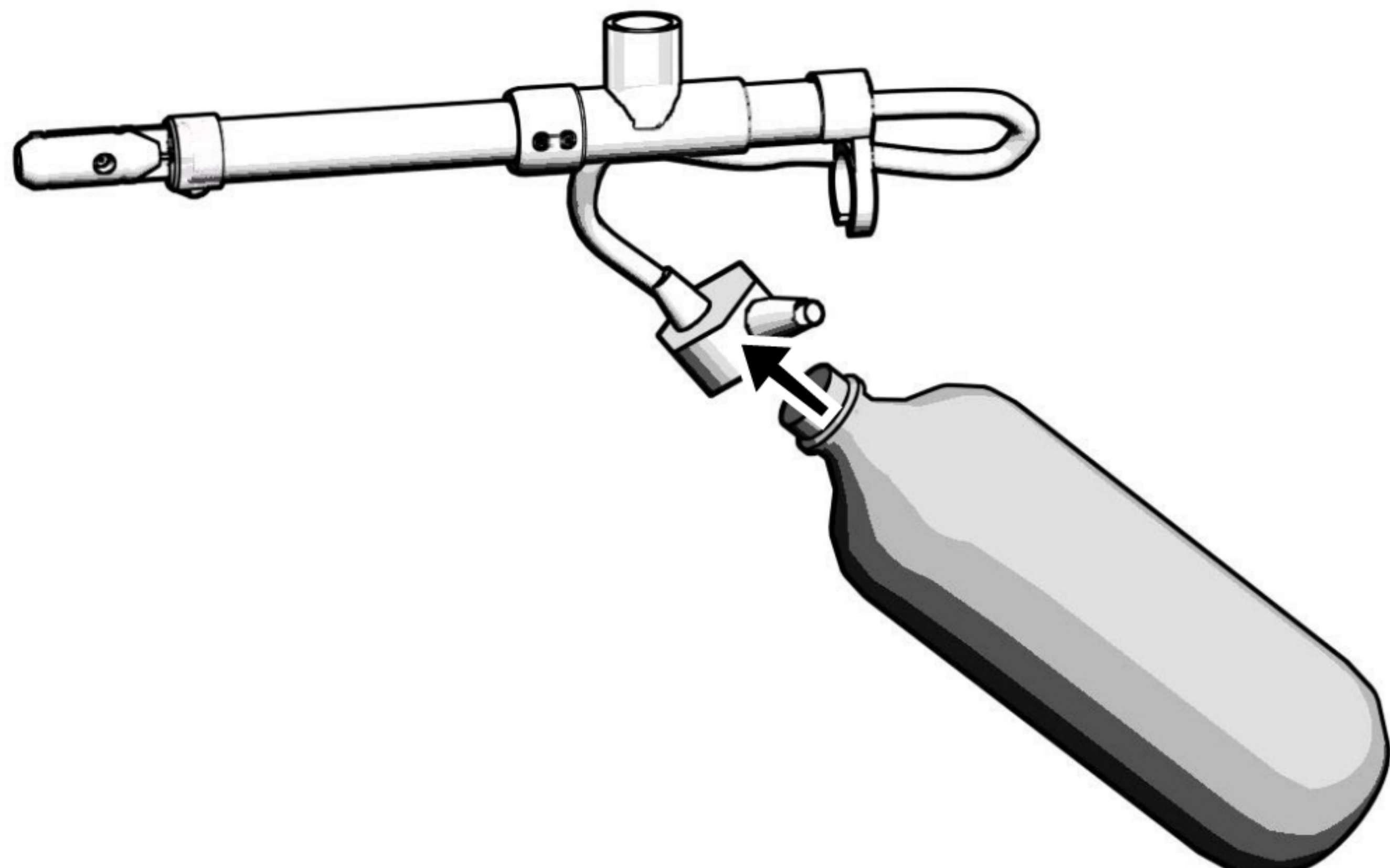

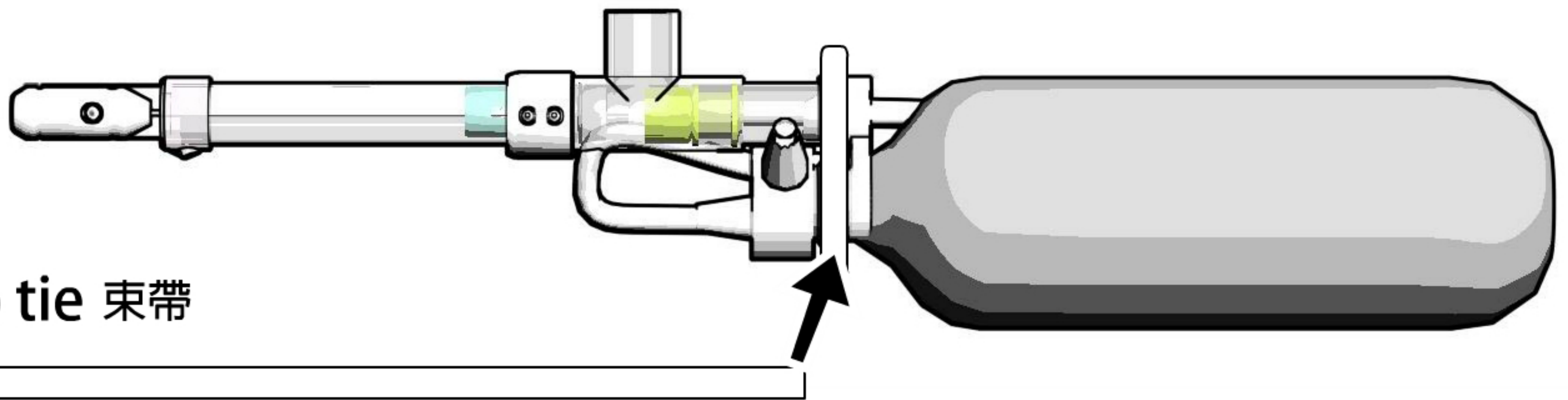
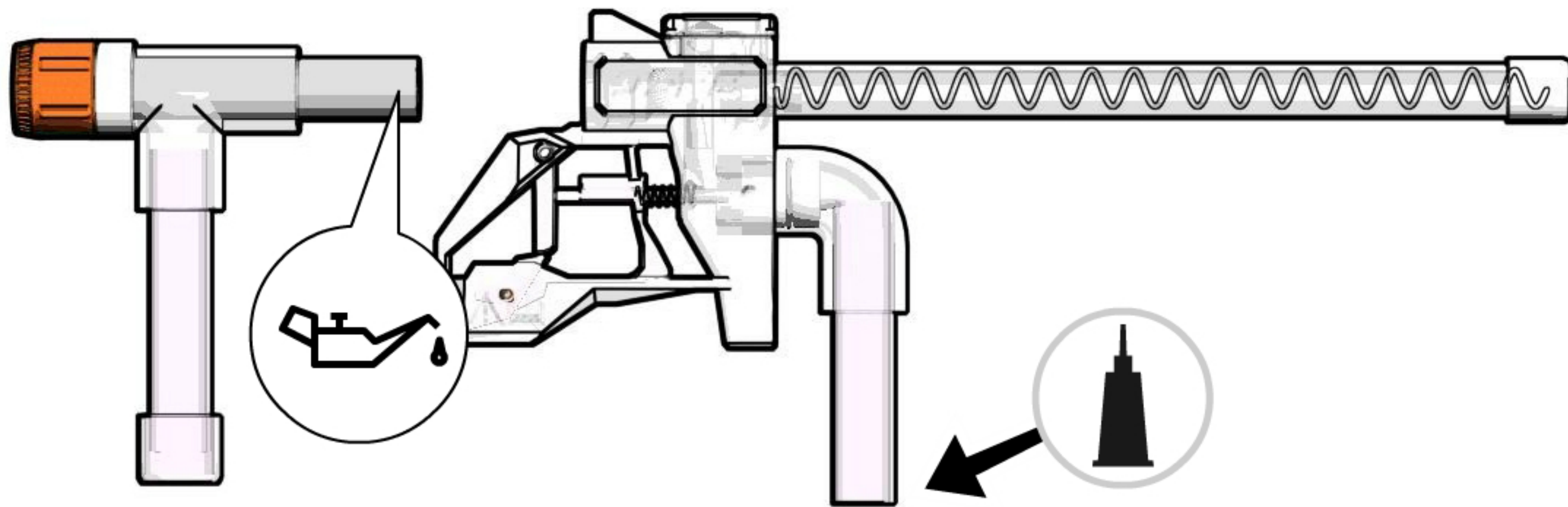
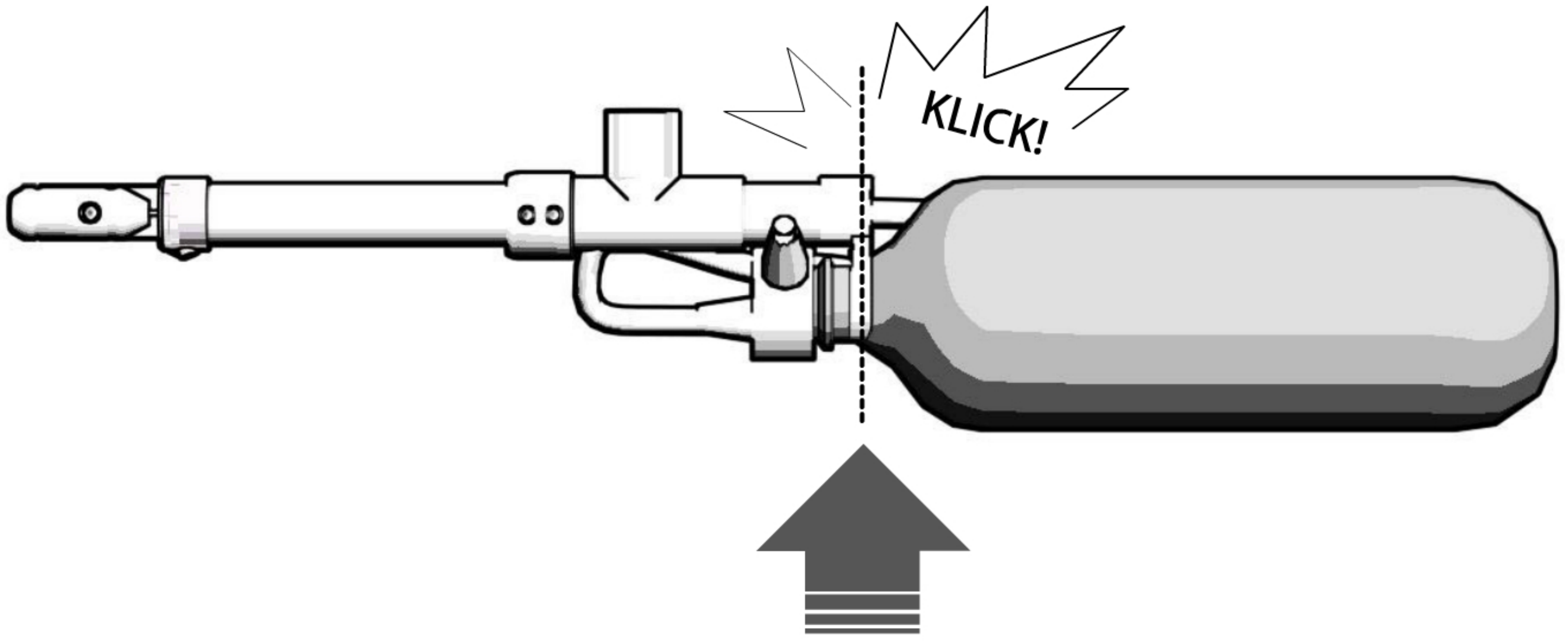

Zip tie 束带

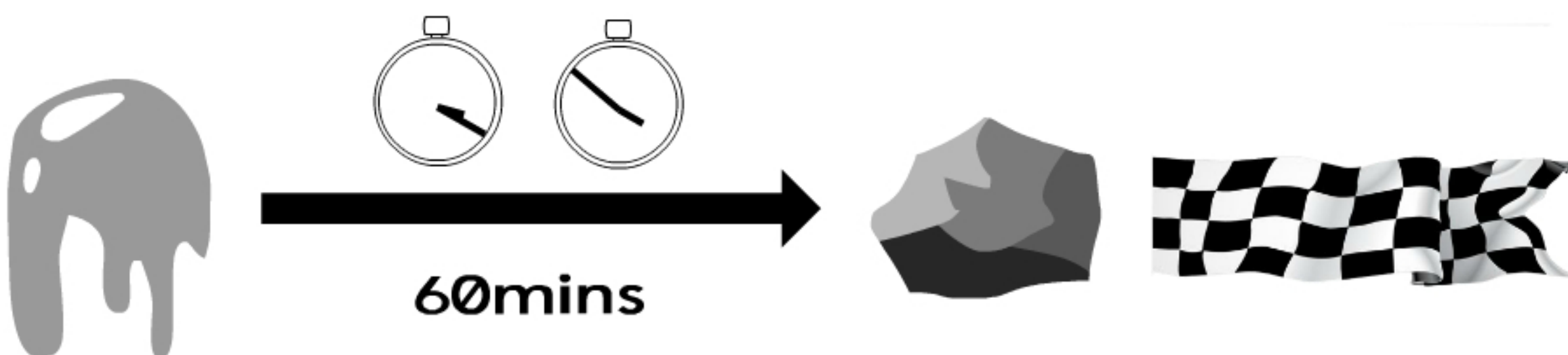
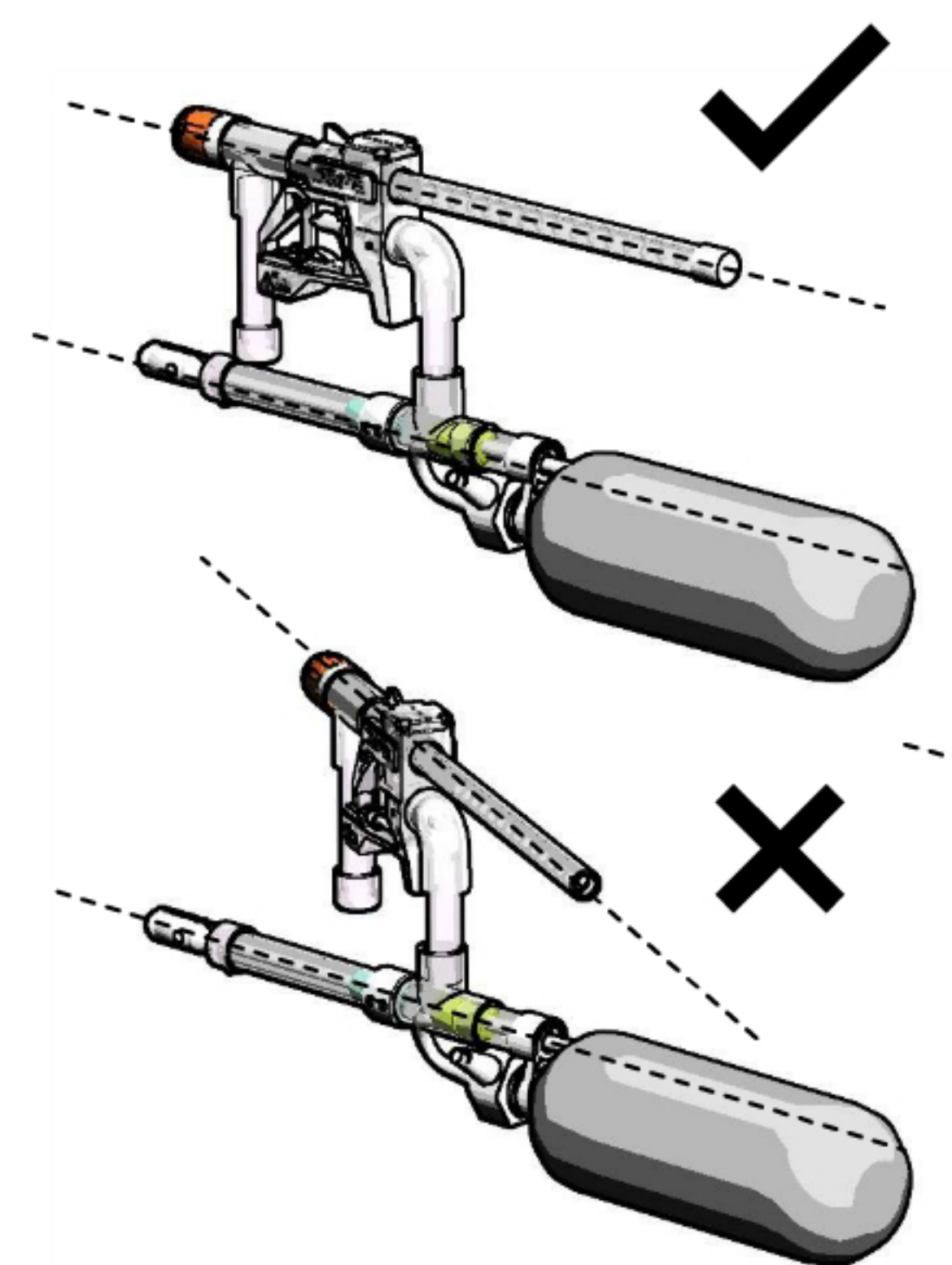
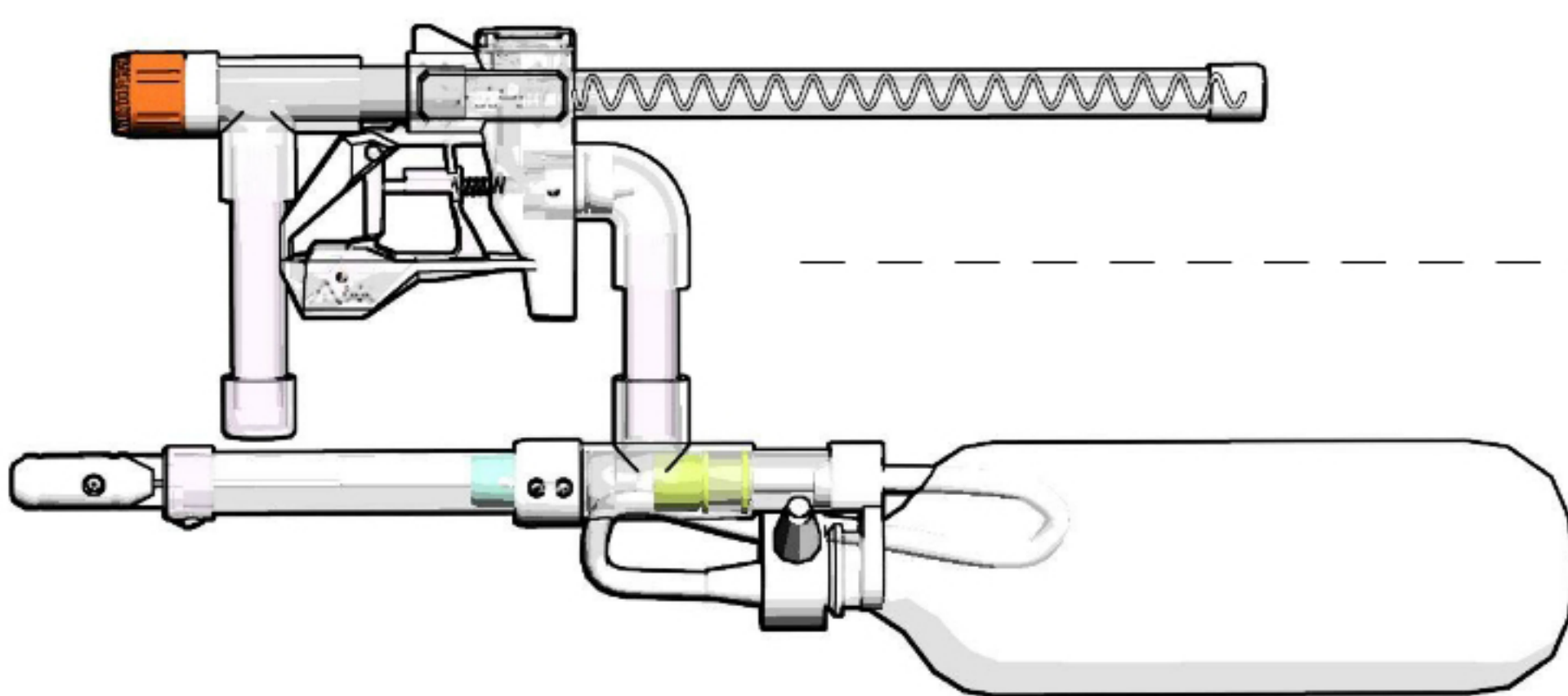

完成!
Congratulations!

TO USE YOUR BLASTER:

1. Load all 6 Short Dart into the chamber.
2. Put on the barrel.

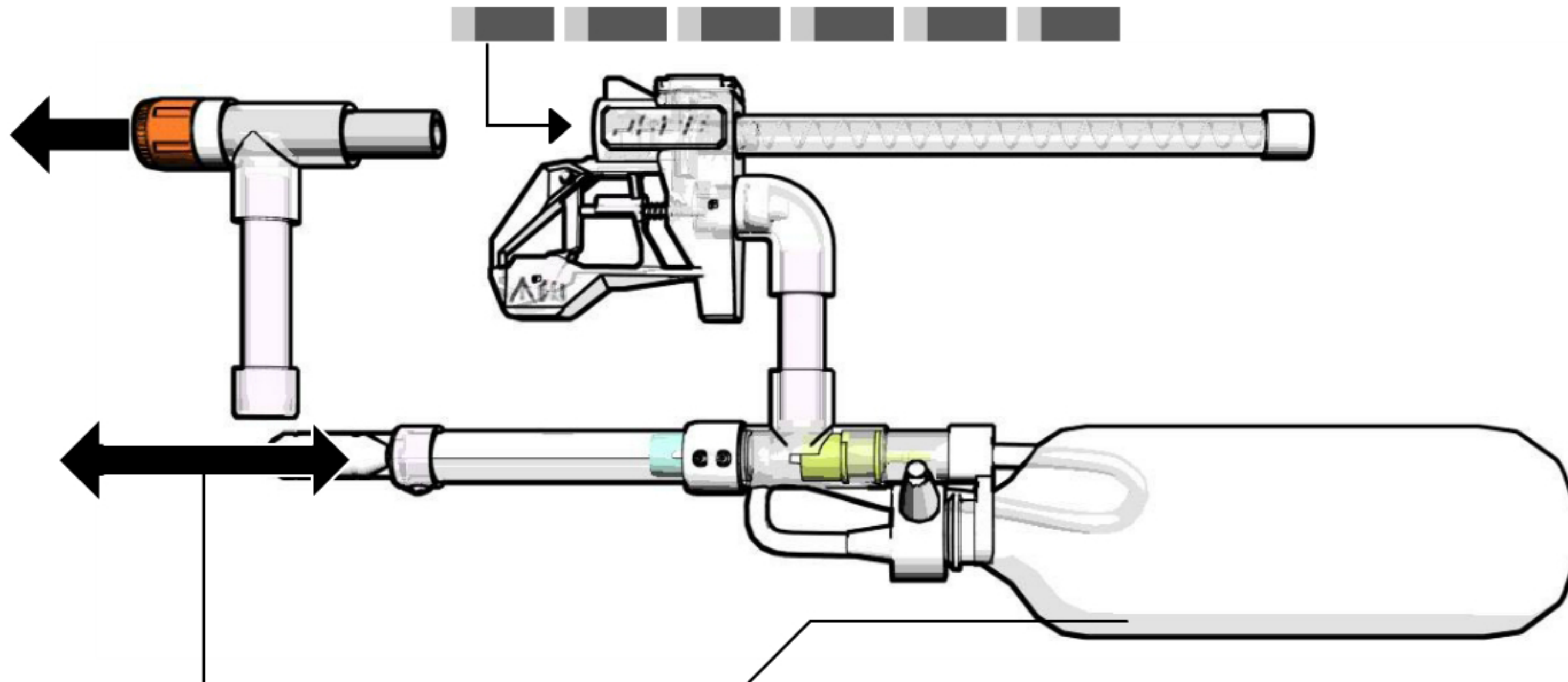

21	300ml	=	6 Shots
41	500ml	=	8 Shots
81	1L	=	16 Shots

3. PUMP THE SODaMAXXX(500ml) Blaster 41 Times to Pressurize.
4. Pulling the trigger fast to launch 1 dart. (90~115 FPS)

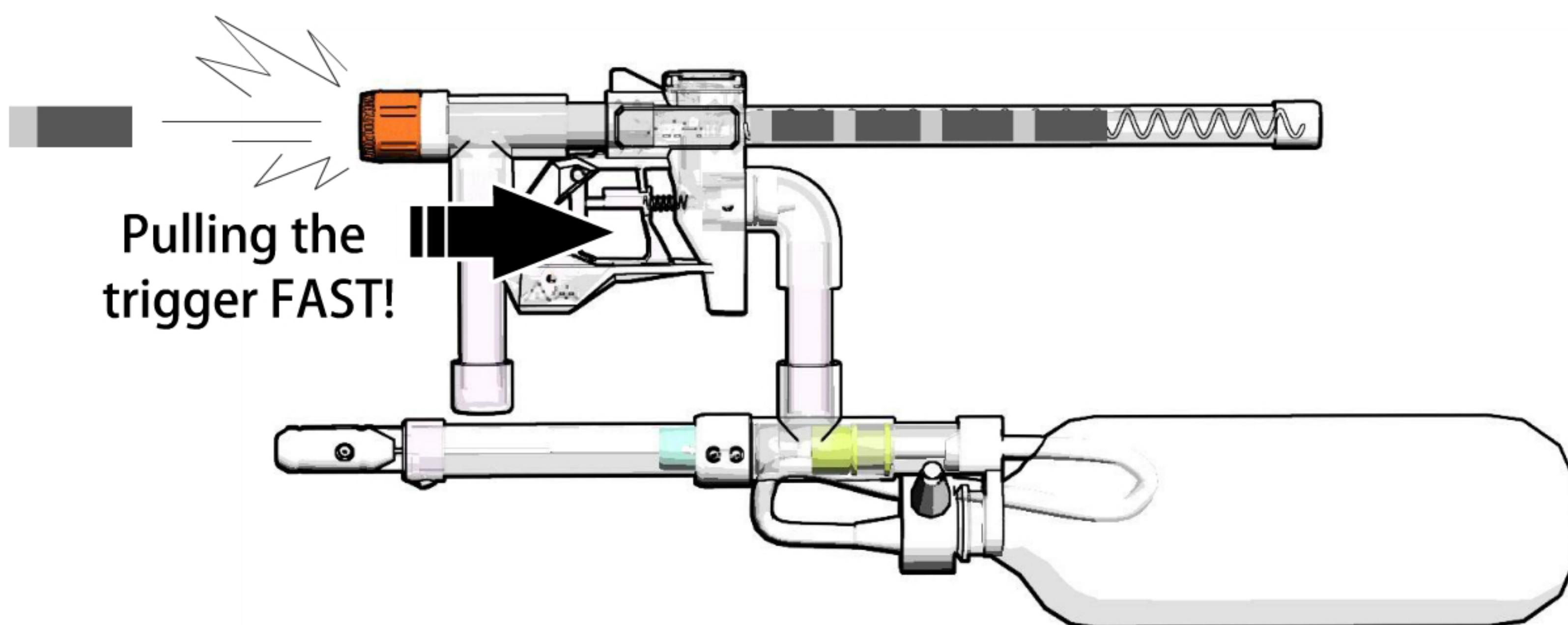

1. 拔下前端槍管將6發短彈塞入膛室。
2. 裝上前槍管
3. 打氣41下到500ml寶特瓶增加壓力。
4. 快速扣下扳機可發射1發,壓力足夠可半自動持續發射 (90~115 FPS)

FAQ:

常見問題

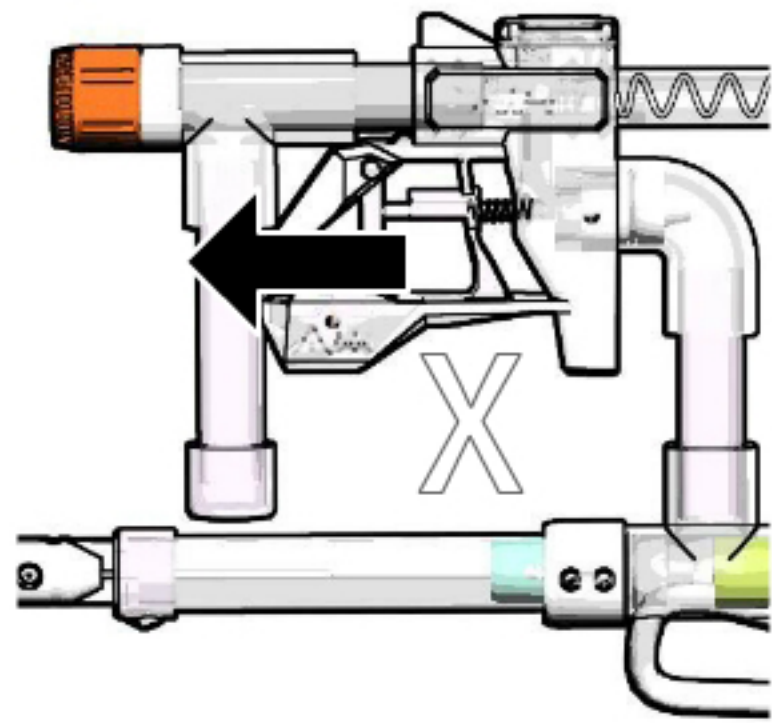

Q1: Trigger won't return.

A1: This may occur after prolonged use, Please wash off the dirt or re-lubricate.

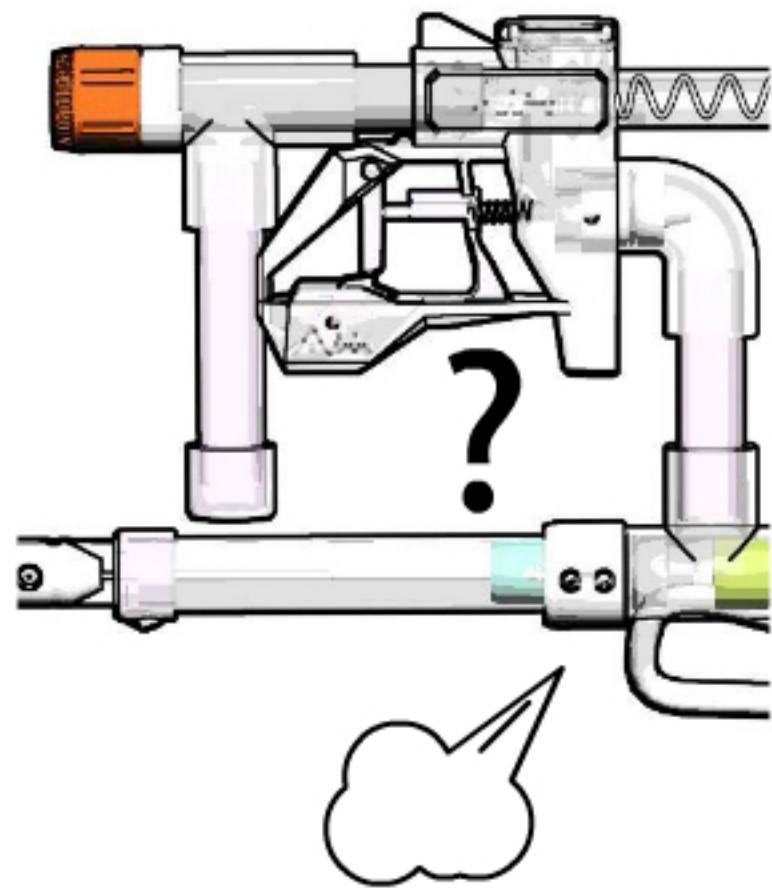

Q2: Blaster unable to hold air pressure.

A2: 1. Please soak the Blaster in water to check for air leaks. 2. reinstall a new Air fuse . 3. Adjust the screw of the adjustment lever (Page8) Adjust the screw to be shorter. 4. The valve is tilted, please adjust it manually and use the air pressure to push the valve body.

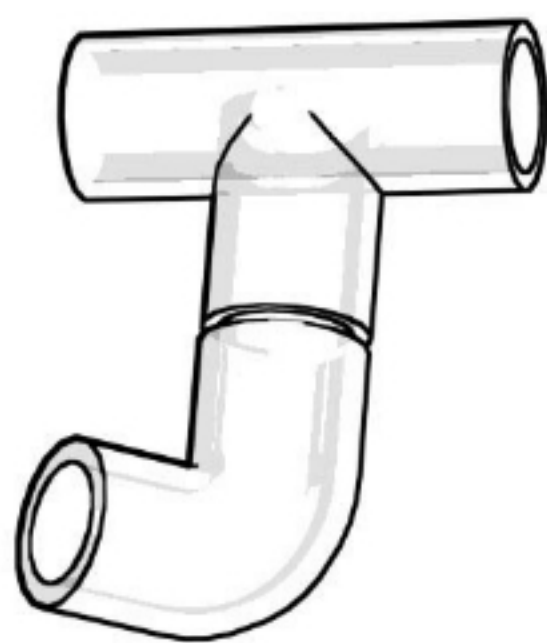

Q3: I broke a part during installation, what should I do?

A3: You can buy separate parts, Please let us know. You can contact us through SNS or JSPB3D.com (It is possible to become SPAM through EMAIL)

問1: 扳機不會回彈。

答1: 檢查是否表面不平順,使用砂紙打磨. 使用過後一段時間泥沙也會導致不順,清洗並重新潤滑即可。

問2: 無法緒氣壓。

答2: 放入水里檢查是否漏氣,重新安裝把特瓶,重新更換空氣保險絲. 參考第八頁可以微調槓桿上的螺絲,將槓桿上的螺絲調整較短.閥門傾斜,請手動調整並搭配打氣筒緒壓來推動閥門本體。

問3: 安裝過程弄壞了零件,怎麼辦?

答3: 請使用社群媒體連繫我們,將零件拍照,我們會針對壞掉的零件報價,電子郵件可能被歸類垃圾信件。

JET LAB Φ

If there is any question, please let me know.



How do I increase the range of my Blaster?

JET實驗室出題:
如何增加威力呢?

find the answer:



Follow
JSPB !

分享你的作品:

找答案: JSPB TAIWAN

#JSPB3D

JSPB JET-LABΦ SODAMAXXX

